

mikropor

Manufacturing Forward

COMPRESSED AIR SYSTEMS

PRODUCT CATALOG



mikropor

01	COMPANY INTRODUCTION	05
02	FILTRATION AND SEPARATION	07
03	COMPRESSED AIR DRYERS	36
04	GAS PRODUCTION AND TREATMENT SYSTEMS	66



COMPANY INTRODUCTION



Mikropor began its journey in 1987 with a passion to create “tomorrow’s technology” and has become one of the leading manufacturers of atmospheric air filtration solutions and compressed air treatment systems for a variety of industries.

By closely following the latest developments in technology, Mikropor’s “Best in Class” products and solutions are appreciated by customers in more than 140 countries.

The company’s sustainable growth has been provided by its passion for innovation and commitment to quality, as well as its dedication to technology. Mikropor is an environmentally conscious company that values people, while developing products that extend the needs and expectations of customers.

With this mission, Mikropor continues to become one of the most recognized brands in the world by expanding its global penetration in the field of technological filtration and contributes to a healthier planet.

02

FILTRATION AND SEPARATION

AIR FILTERS	8
MIFH SERIES MIKROLINE AIR INTAKE FILTERS	9
MAFH SERIES MAKROLINE AIR INTAKE FILTERS	10
AIR/OIL SEPARATORS	12
AIR FILTER ELEMENTS	14
REPLACEMENT ELEMENTS	16
G WS Series WATER SEPARATORS	17
F WS SERIES FLANGED WATER SEPERATORS	18
GON SERIES COMPRESSED AIR FILTERS	20
F SERIES FLANGED AIR FILTERS	26
ELM SERIES MIST ELIMINATOR AIR FILTERS	28
HP&HGH SERIES HIGH PRESSURE AIR FILTERS	30
MCC SERIES CATALYTIC CONVERTER	32



FILTRATION AND
SEPARATION

Air Filters for Air Compressors

Mikropor Air Filters are the first line of defence for any air compressor and have a significant impact on the service life of the compressor, lubricant, air/oil separators and oil filters.

Mikropor offers the highest efficiency air intake filters in the market, outperforming the competition and delivering more value to customers.

Micro-Glass and Mini-Pleat System in Air Filters

Our Micro-Glass Mini-Pleated Air Filters reach a 99.99% efficiency faster than cellulose air filters and provide better protection by allowing fewer contaminants to pass through the media.

Mikropor Nano Media holds up to five times more contaminants than conventional cellulose air filters, making them ideal for extended maintenance periods.



The Mikropor Mini-Pleat system guarantees equal space between each filter pleat and maintains "V" pleated geometry throughout the service life of the filter. As a result, 100% of the surface area performs equally and delivers the expected protection, while minimizing pressure drops.



► MIFH SERIES MIKROLINE AIR INTAKE FILTERS

FILTRATION AND SEPARATION ◀

Mikropor's air intake elements are designed for the removal of dust or particulate in the air intake systems of compressors, machines, pumps, blowers, etc. Based on the density of the dust load, Mikropor offers two series with different sizes and capacities: Mikroline and Makroline.

Applications

Mikroline Air Intake Filters are well suited for applications with low dust loads such as power generators, piston compressors, as well as air cleaner ventilation of gear units and the filtration of liquid tanks.

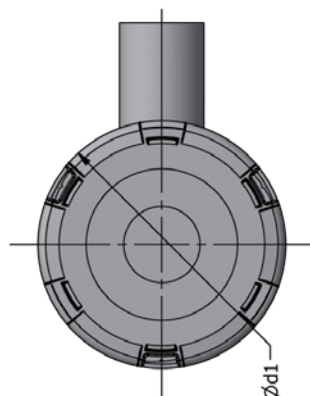
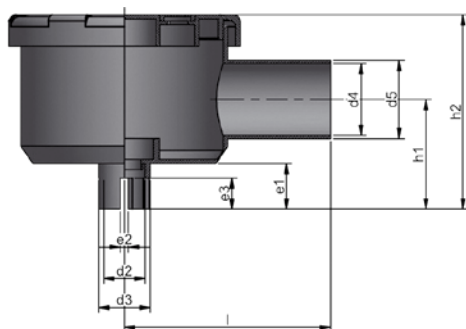

General Working Conditions

Type	Overall Design	Volumetric Flow Range	Continuous Operating Temperature	Short Time Maximum Operating Temperature
Mikroline Air Intake Filters	Highly Reliable Plastic Air Cleaner Housing with High Quality element	1 m ³ /min to 4 m ³ /min	-30°C to +100°C	+120°C

Dimensions

Model	d1	d2	d3	d4	d5	e1	e2	e3	e4	h1	h2	l	Nominal Flow Rate (m ³ /min)	Compressor Connection Type
MIFH-0120	112	20	25	35	38	22	4	15	-	53	94	100	1	Internal Tightened
MIFH-0130	112	30	35	35	38	22	4	15	-	53	94	100	1	Internal Tightened
MIFH-0140	112	40	45	35	38	22	4	15	-	53	94	100	1	Internal Tightened
MIFH-0240	140	40	45	35	38	22	4	15	-	67	114	120	2	Internal Tightened
MIFH-0248	140	48	53	35	38	22	4	15	-	67	114	120	2	Internal Tightened
MIFH-0252	140	52	57	35	38	22	4	15	-	67	114	120	2	Internal Tightened
MIFH-0260	140	60	65	35	38	22	4	15	-	67	114	120	2	Internal Tightened
MIFH-0271	140	71	76	35	38	22	4	15	-	67	114	120	2	Internal Tightened
MIFH-0440	181	40	45	58	60	22	4	15	-	102	164	154,5	4	Internal Tightened
MIFH-0452	181	52	57	58	60	22	4	15	-	102	164	154,5	4	Internal Tightened
MIFH-0460	181	60	65	58	60	22	4	15	-	102	164	154,5	4	Internal Tightened
MIFH-0462	181	62	67	58	60	22	4	15	-	102	164	154,5	4	Internal Tightened
MIFH-0468	181	68	73	58	60	22	4	15	-	102	164	154,5	4	Internal Tightened
MIFH-0471	181	71	76	58	60	22	4	15	-	102	164	154,5	4	Internal Tightened
MIFH-0475	181	75	78	58	60	22	4	15	-	102	164	154,5	4	Internal Tightened
MIFH-0478	181	78	83	58	60	22	4	15	-	102	164	154,5	4	Internal Tightened

Design

Mikropor Makroline Air Intake Filters are designed to provide maximum performance for customers with extremely high dust capacity and low pressure drop air intake filter demands. Makroline filters are also suitable for use in higher temperature environments.

Applications

Mikropor Makroline Air Intake Filters are designed for medium and heavy dust load conditions for applications such as Air Compressors, Construction Machines, Agricultural Machines, Harvesting Machines, etc.

Advantages

The advantages of Makroline Air Intake Filters are:

- Operational reliability,
- Long service life thanks to its highly efficient and reliable filter elements,
- Low pressure drop,
- Impact resistant corrosion free housing polypropylene,
- Excellent price/performance ratio.

Mikropor Makroline Air Intake Filters' user friendly and flexible bracket system provides the ability for easy installation. The brackets can be turned in various positions, providing numerous fitting possibilities. Mikropor's versatile production offers these brackets in different sizes.



Easy and various mounting possibilities

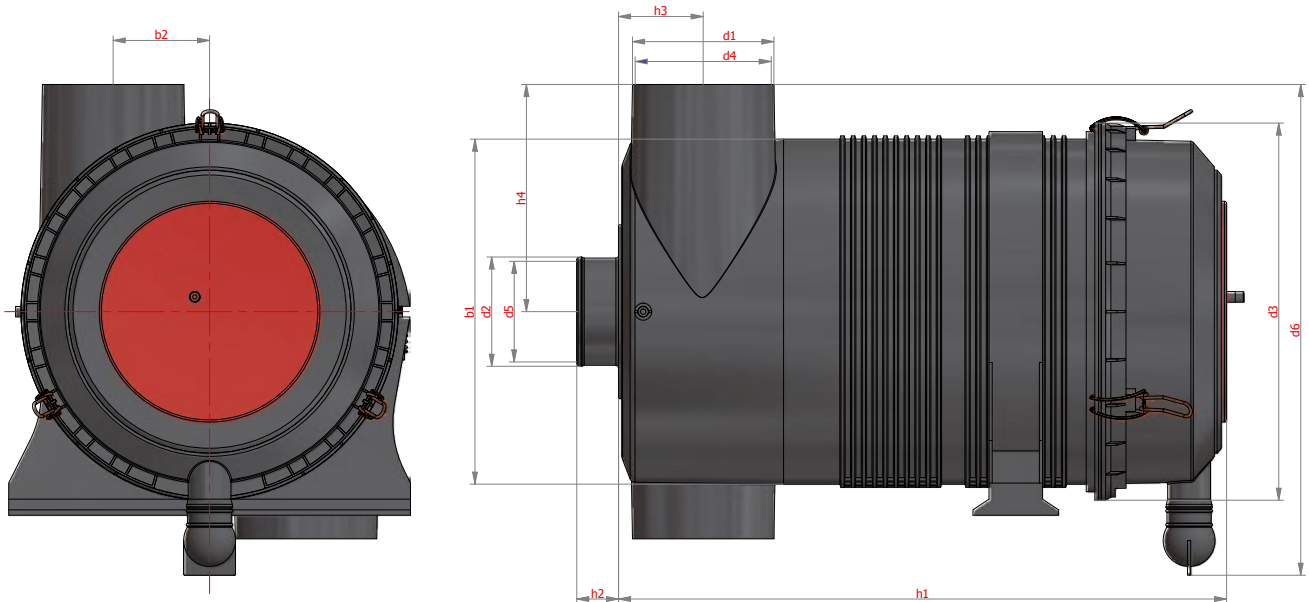

General Working Conditions for Makroline Air Intake Filters

Type	Overall Design	Volumetric Flow Range (m ³ /min)	Continuous Operating Temperature	Short Time Maximum Operating Temperature
Makroline Air Intake Filters	Highly Reliable Plastic Air Cleaner Housing with High Quality Element Center Tube in Housing Radial Seal	3 m ³ /min to 28 m ³ /min	-30°C to +80°C	+100°C

Technical Specifications

Model	b1	b2	d1	d2	d3	d4	d5	d6	h1	h2	h3	h4	Nominal Flow Rate (m ³ /min)	Compressor Connection Type
MAFH-18100	322	90	132	100	352	127	95	458	417,5	39	79	212	18	External Clamped
MAFH-18110	322	90	132	110	352	127	105	458	417,5	39	79	212	18	External Clamped
MAFH-18130	322	90	132	130	352	127	125	458	417,5	39	79	212	18	External Clamped
MAFH-18150	322	90	132	150	352	127	145	458	417,5	39	79	212	20	External Clamped
MAFH-20100	322	90	132	100	352	127	95	458	447,5	39	79	212	20	External Clamped
MAFH-20110	322	90	132	110	352	127	105	458	447,5	39	79	212	20	External Clamped
MAFH-20130	322	90	132	130	352	127	125	458	447,5	39	79	212	22	External Clamped
MAFH-20150	322	90	132	150	352	127	145	458	447,5	39	79	212	22	External Clamped
MAFH-22100	322	90	132	100	352	127	95	458	477,5	39	79	212	22	External Clamped
MAFH-22110	322	90	132	110	352	127	105	458	478	39	79	212	22	External Clamped
MAFH-22130	322	90	132	130	352	127	125	458	478	39	79	212	24	External Clamped
MAFH-22150	322	90	132	150	352	127	145	458	478	39	79	212	24	External Clamped
MAFH-24100	322	90	132	100	352	127	95	458	508	39	79	212	24	External Clamped
MAFH-24110	322	90	132	110	352	127	105	458	508	39	79	212	24	External Clamped
MAFH-24130	322	90	132	130	352	127	125	458	508	39	79	212	26	External Clamped
MAFH-24150	322	90	132	150	352	127	145	458	508	39	79	212	26	External Clamped
MAFH-26100	322	90	132	100	352	127	95	458	538	39	79	212	26	External Clamped
MAFH-26110	322	90	132	110	352	127	105	458	538	39	79	212	26	External Clamped
MAFH-26130	322	90	132	130	352	127	125	458	538	39	79	212	28	External Clamped
MAFH-26150	322	90	132	150	352	127	145	458	538	39	79	212	28	External Clamped
MAFH-28100	322	90	132	100	352	127	95	458	568	39	79	212	28	External Clamped
MAFH-28110	322	90	132	110	352	127	105	458	568	39	79	212	28	External Clamped
MAFH-28130	322	90	132	130	352	127	125	458	568	39	79	212	28	External Clamped
MAFH-28150	322	90	132	150	352	127	145	458	568	39	79	212	28	External Clamped

Why Mikropor Separators?

With over 3000 Air/Oil Separator designs for compressors, Mikropor offers multiple options for the full range of air flow and performance requirements.

Mikropor Air/Oil Separators

Conventional, pleated, depth construction, spin-on and state-of-the-art "sep-n-sep" design separators allow Mikropor to cover the air/oil separation needs of the entire compressor applications.



Air Flow Rates of Mikropor Air/Oil Separators (m³/min @ 7 bar working pressure)

Dimensions

Air/Oil Separator Overall Height (mm)

		150	200	250	300	350	400	450	500	550	600	650	700	750	800	850	900	950	1000	
110	Conventional	1	2	2																
	3S	3	5	5																
	Sep-n-Sep®																			
135	Conventional	2	2	3	3	4	5													
	3S	4	5	6	8	8	9													
	Sep-n-Sep®																			
150	Conventional	2	2.5	3	4	5	5	6	7											
	3S	4	5	7	8	10	11	12	13											
	Sep-n-Sep®																			
170	Conventional	2	3	4	5	5	6	7	8	9	9									
	3S	4	6	8	10	11.5	13	14	16	17	19									
	Sep-n-Sep®																			
200	Conventional		3	5	5	7	7	8	9	10	11	12								
	3S		7	9	11	13	15	17	19	21	23	25								
	Sep-n-Sep®																			
220	Conventional			5	6	7	8	9	11	12	13	14	15	16						
	3S			10	13	15	17	19	22	23	26	28	30	33						
	Sep-n-Sep®																			
270	Conventional			7	8	9	10	12	13	15	16	17	19	20	22	23	24			
	3S			14	15	18	21	24	27	29	32	35	38	41	44	47	49			
	Sep-n-Sep®			21	23	27	31	36	40	44	48	52	56	61	66	70	73			
300	Conventional			8	9	10	12	13	15	17	18	20	21	23	24	26	28	29	31	
	3S			15	18	21	24	27	30	34	37	40	43	46	49	53	57			
	Sep-n-Sep®			24	28	32	37	41	46	53	57	62	66	71	76	82	88			
350	Conventional			10	12	14	16	18	20	22	24	26	28	30	32	34	36	38	38	
	3S			20	24	28	32	36	40	44	48	52	56	60						
	Sep-n-Sep®			32	38	44	50	56	63	69	75	81	88	94						
375	Conventional			11	13	15	17	19	21	23	25	27	29	32	33	35	37	39		
	3S			22	26	30	34	38	42	46	50	54	58							
	Sep-n-Sep®			34	40	47	54	60	66	72	79	85	91							
400	Conventional				15	17	19	21	23	25	27	29	32	34	36	38	40	42		
	3S				30	34	37	42	46	51	55	59								
	Sep-n-Sep®				47	52	59	67	73	81	88	94								
470	Conventional				20	22	25	27	30	33	35	37	41	43	45	48	51	54	56	
	3S				40	45	50	55												
	Sep-n-Sep®				63	71	79	87												
500	Conventional				24	27	30	33	36	39	42	45	48	51	54	56				
	3S				50	55	60													
	Sep-n-Sep®				82	91	100													

Conwrap Separators

Mikropor "Conwrap" Separators are standard wrapped style separators. These separators are designed for outside to inside flow and can be used with all oil injection Rotary Vane and Rotary Screw Compressors. Conwrap separators operate between 1 to 60 m³/min flow rate at 7 bar with 1 to 3 mg/m³ oil carry over.

"3S" Depth Construction Air/Oil Separators

The revolutionary Mikropor "3S" Separator is designed to fit the smaller separator housings without sacrificing operating performance. The "3S" separator has double to tripled capacity when compared to a conventional separator with the same dimensions. The "3S" separator has 1/2 - 1/3 of the volume of a conventional separator functioning in the same operating conditions. This increased capacity is achieved with specially designed progressive type, deep bed, coalescing media using an increased number of wraps.

Pleated Air/Oil Separators

Pleated separators increase the media surface area to reach higher capacities while maintaining the dimensions. Mikropor manufactures dozens of pleated separator designs.



CONWRAP



3S - SEPARATORS



PLEATED

Zero Spin-On Type Air/Oil Separators

Mikropor Spin-On Type Air/Oil Separators are manufactured as exchangeable elements. Because Spin-Ons do not require a compressor housing, they permit uncomplicated and quick replacement without dismantling the compressor. Spin-On Type Air/Oil Separators are available for 0,5 to 7 m³/min flow rates operating at 7 bar.

Model	Maximum Flow Rate (m ³ /min @ 7 bar)	Dia 1 (mm)	Dia 2 (mm)	Height (mm)
Zero 10	0,5	Ø79	Ø80	84
Zero 20	1	Ø79	Ø83	137
Zero 30	2	Ø97	Ø100	214
Zero 40	1.5	Ø97	Ø100	175
Zero 50	4	Ø110	Ø111	261
Zero 60	3	Ø138	Ø141	192
Zero 70	6	Ø138	Ø141	314
Zero 80	7	Ø138	Ø141	349

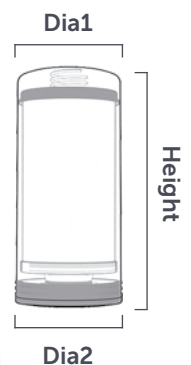

▶ AIR FILTER ELEMENTS

Micro-Glass Fiber

High efficiency Micro-Glass nanofiber media (80 times finer than Cellulose Fiber) delivers higher targeted efficiencies, longer service life, wide chemical and synthetic lubricant compatibility even at extreme working temperatures.

Element 4 Levels

Mikropor offers four layers of Superior Protection—from 1 micron to 0.01 micron. Durable element construction and an efficient drain layer ensure continued performance with optimal element change periods.

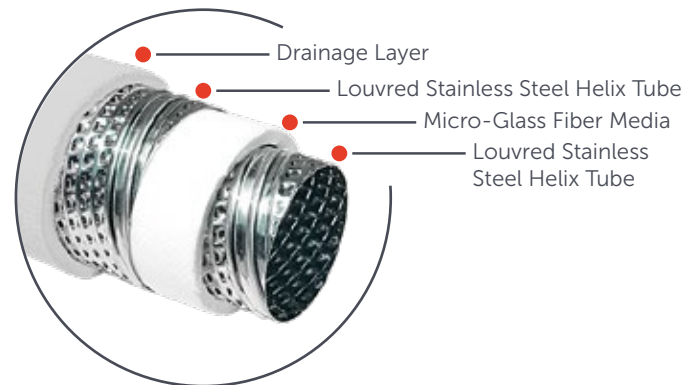

Helix Tubes for Strength

Mikropor Compressed Air Filters have louvred stainless steel helix tubes providing increased strength and protection against severe pressure drops while improving performance by forcing air to pass diagonally through the element.

Synthetic Compatibility and Durable Epoxy

Mikropor Compressed Air Filters are compatible with all synthetic lubricants in the industry. Durable Epoxy securely bonds the robust end caps to the filter tubes and will not be affected by the synthetic lubricant in compressed air.



Test

With over 30 years of experience Mikropor manufactures the best performing replacement elements in the industry. Through rigorous testing and validation processes Mikropor assures that the replacement elements perform equal to or better than the original elements. Replacement elements have been designed and tested in our state-of-the-art test laboratories.

Mikropor labs are capable of making the following tests;

- Differential pressure at given flow rates
- Particle efficiency tests
- Oil aerosols measurements
- Pressure dew point

All tests are conducted as per the relevant ISO 12500 test standards.



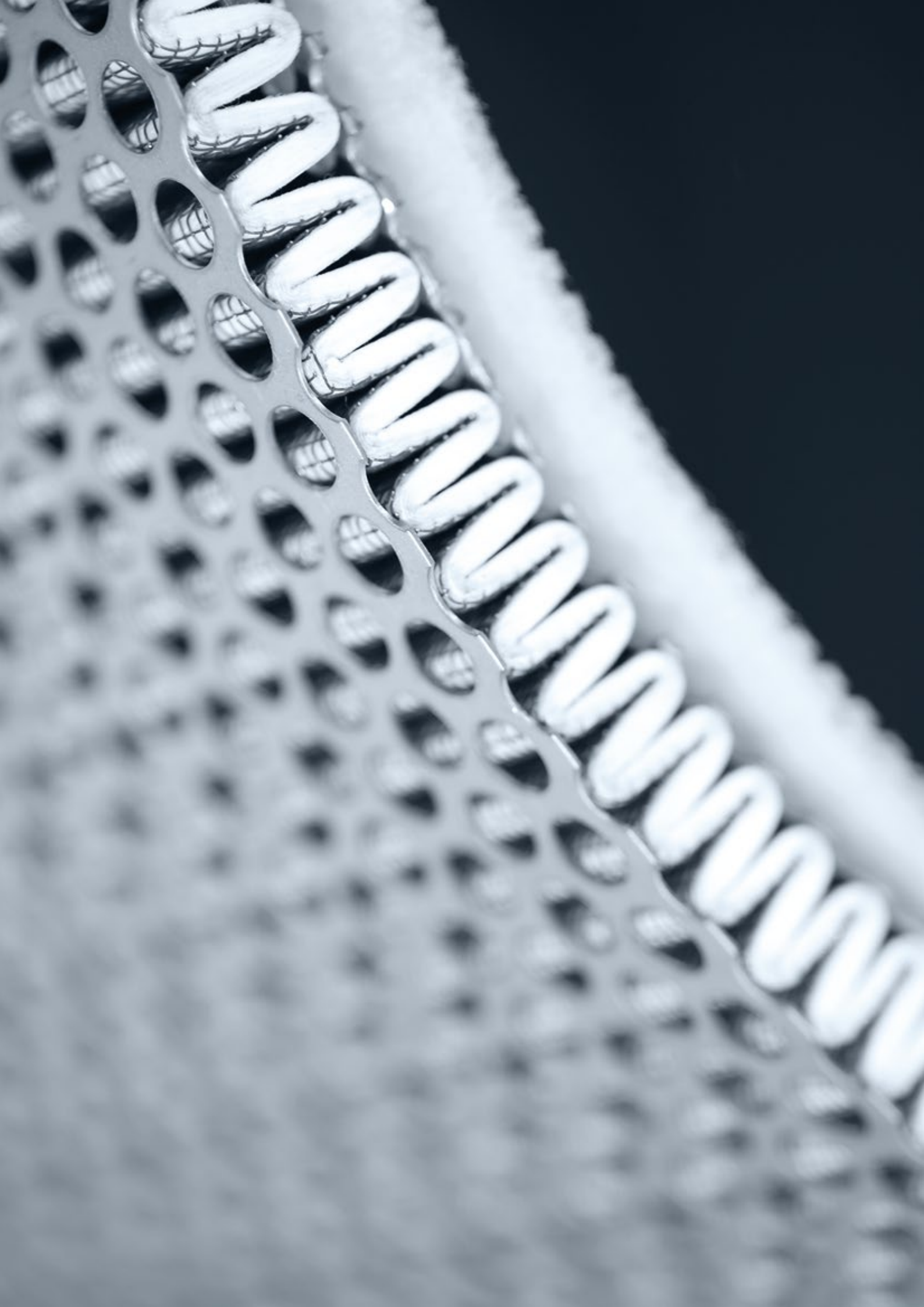



- ALMIG
- ATLAS COPCO
- BEA
- COMPAIR
- DELTECH
- DOMNICK HUNTER
- DOMNICK HUNTER (Evolution Range)
- FAI FILTER
- HANKISON
- HIROSS
- KAESER
- MTA
- OMI
- ULTRA FILTER
- WALKER
- ZANDER



Mikropor water separators have been designed for the removal of bulk liquid water and particulate from compressed air and gases. Unique centrifugal action removes contaminants at low-pressure drop for maximum energy saving.

Mikropor water separators are available from 1/4"-3" pipe sizes and for flows up to 2200 m³/h (1294 cfm).

Note: While highly efficient, condensate separators will not remove 100% of the oil from the air stream. Additional coalescing and particulate filters downstream may be required to remove the fine traces of oil, water and particles.

Note: Automatic drain valves are fitted as standard. All separator bodies are coated with electrostatic powder paint finish both inside and out.

Correction Factor

For maximum flow rate, multiply model flow rate show in the above table by the correction factor corresponding to the working pressure.

Operating Pressure (bar)	Psi	Correction Factor
1	15	0.5
3	44	0.71
5	73	0.87
7	100	1
9	131	1.12
11	160	1.22
13	189	1.32
15	218	1.44
16	247	1.57



Technical Specifications

For maximum flow rate, multiply model flow rate show in the above table by the correction factor corresponding to the working pressure.

Model	Connection Size	Flow Rate		Housing Dimensions (mm)			
		(m ³ /h)	(cfm)	A	B	C	D
G25WS	1/4"	25	14	103	257.5	236	160
G100WS	1/2"	100	58	103	257.5	236	210
G200WS	3/4"	200	117	123	304	277	285
G300WS	1"	300	176	123	304	277	380
G600WS	1 1/2"	600	353	123	320	285	470
G1200WS	2"	1200	706	160	484	443	560
G2200WS	3"	2200	1294	193	546	490	610

Max. Recommended Operating Temperature	Min. Recommended Operating Temperature	Typical Pressure Loss at Rated Flow	Max. Working Pressure
80°C	1.5°C	50 mbar	16 bar

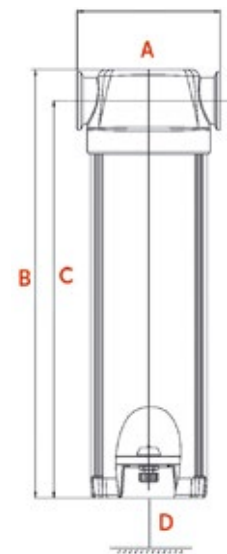

Given flows are at 7 barg pressure with reference to 20°C and 1 bar atmospheric air suction as per ISO7183.

Mikropor flanged water separators have been designed for the removal of bulk liquid water and particulate from compressed air and gases. Unique centrifugal action removes contaminants at low-pressure drop for maximum energy savings. Mikropor flanged water separators are available from DN80-DN200 flange sizes and flows up to 14000 m³/h (8236 cfm) **(For larger sizes please contact our sales team).**

Note: While highly efficient, condensate separators will not remove all of the oil from the air stream. Additional coalescing and particulate filters downstream may be required to remove the fine traces of oil, water and particles.

Correction Factor

For maximum flow rates, multiply model flow rate show in the above table by the correction factor corresponding to the working pressure.

Operating Pressure (bar)	PSI	Correction Factor
1	15	0.5
3	44	0.71
5	73	0.87
7	100	1
9	131	1.12
11	160	1.22
13	189	1.32
14	200	1.38

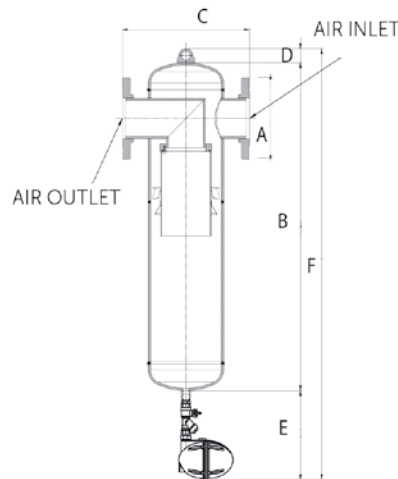

Max. Recommended Operating Temperature	Min. Recommended Operating Temperature	Typical Pressure Loss at Rated Flow	Max. Working Pressure
80°C	1.5°C	50 mbar	14 bar

Technical Specifications

Model	Connection Size	Flow Rate		Housing Dimensions (mm)					
		(m ³ /h)	(cfm)	A	B	C	D	E	F
F-2500WS	DN80	2500	1407.5	200	934	450	75	280	1289
F-3200WS	DN100	3200	1882.3	220	964	450	75	280	1319
F-4300WS	DN100	4300	2529.4	220	982	530	75	280	1283
F-6500WS	DN150	6500	3823.5	285	1092	580	75	280	1447
F-8500WS	DN150	8500	5000	285	1091	650	75	280	1446
F-11000WS	DN200	11000	6470.5	340	1168	750	75	280	1523
F-14000WS	DN200	14000	8235.2	340	1201	800	75	280	1556

Given flows are at 7 bar pressure with reference to 20°C and 1 bar atmospheric air suction as per ISO7183.

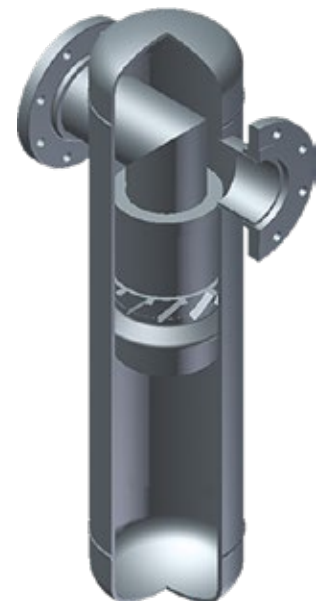



GON Series

Mikropor, which constantly develops products beyond expectations and needs, has recently begun manufacturing the brand new GON Series Industrial Air Filters for compressed air users to acquire high efficiency filtration experience at the lowest pressure drops.

The new GON Series have more port sizes and offer a reliable performance by minimizing airborne contamination in Compressed Air Systems to the maximum possible extent. With the GON Series, the compressed air users will have the opportunity to replace the inner element and assemble the filter in any compressed air unit extremely easily by means of an innovative design concept which basically puts its unique **"Zero Clearance"** feature forward.

The GON Series are incredibly economical and also manufactured according to **ISO 8573** standards along with its eligibility for PED due to their sustainable and durable structure which is formed up with aluminium construction.

Features

- 35 m³/h- 1200 m³/h air flow range
- NPT/BSP pipe sizes ranging from 1/4 "to 4"
- Aluminium construction without any pores
- **Options:**
 - "Standard Drain" having 1/2" connection size or
 - "Drainless" having 1/2 connection size with adapter.
- Elegantly designed connection clips and wall apparatus
- Production in accordance with ISO8573
- Zero Clearance
- Anodising
- Lock System Indicator

GON-HC Series

In Addition to GON Series, Mikropor has also developed the GON-HC Series in order to respond to high capacity air pressure needs.

High capacity GON-HC Series Filters are designed to increase the capacity of air filters used in compressed air systems. Thus, the utilization of compressed air volume can be easily pushed up to 5400 m³/h.

Compressed air users will be able to install GON-HC Series in their systems without any need for ASME Standards eligibility requirements.



14 Models Between
35 m³/h - 1200 m³/h



6 Models Between
1550 m³/h - 5400 m³/h

Features

- 1550 m3/h- 5400 m3/h air flow range
- NPT/BSP pipe and DN Flange sizes ranging from 1/4 to 4
- Aluminium construction without any pores
- **Options:**
 - "Standard Drain" having 1/2 connection size or
 - "Drainless" having 1/2 connection size with adapter.
- Elegantly designed connection clips and wall apparatus
- Production in accordance with ISO8573
- Zero Clearance
- Anodising
- Lock System Indicator

GON Series Advantages

- Low initial investment costs
- Low maintenance costs
- Compact design
- Easy to use and install
- High performance
- Third party tested



Purity Class	ISO 8573.1: 2010 Compressed Air Quality Standard							
	Solid Particulate				Water		Oil	
	Max. number of Particles per m ³			Particle Size (micron)	Concentration (mg/m ³)	Vapor Pressure Dew Point	Liquid (g/m ³)	Total Oil (Aerosol, Liquid and Vapor) (mg/m ³)
	0.1-0.5 micron	0.5-1 micron	1-5 micron					
0	As specified and determined by equipment user and supplier							
1	≤20000	≤400	≤10	-	-	≤-70°C	-	≤0.01
2	≤400000	≤6000	≤100	-	-	≤-40°C	-	≤0.1
3	-	≤900000	≤1000	-	-	≤-20°C	-	≤1
4	-	-	≤10000	-	-	≤+3°C	-	≤5
5	-	-	≤100000	-	-	≤+7°C	-	-
6	-	-	-	5	5	≤+10°C	-	-
7	-	-	-	40	10	-	0.5	-
8	-	-	-	-	-	-	5	-
9	-	-	-	-	-	-	10	-

for Solid Particles	for Water	for Oil
Element Type P - Class 3	Mikropor Refrigerated Air Dryers are Class 4	Element Type P - Class 3
Element Type X - Class 2		Element Type X - Class 2
Element Type Y - Class 1	Mikropor Desiccant Air Dryers are Class 1 and 2	Element Type Y - Class 1
Element Type A - N/A		Element Type A - Class 1 (when used with Y)

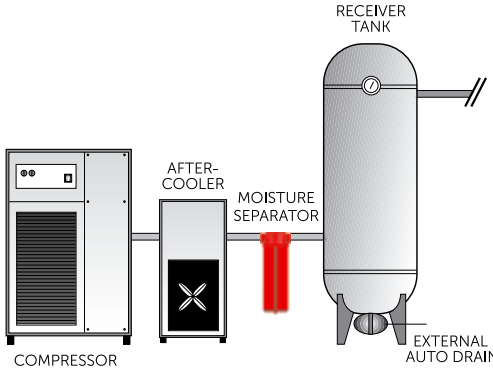
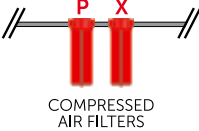
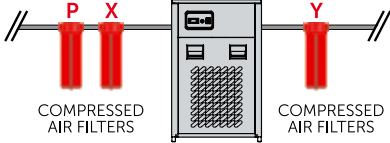
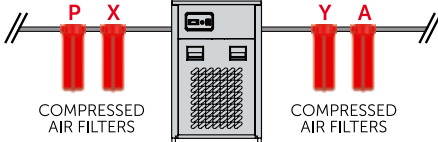
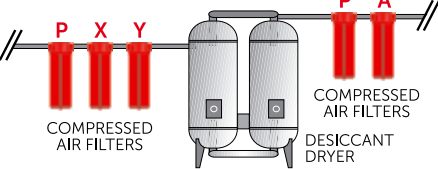
AIR LINE DESIGN	AIR LINE DESIGN 1	APPLICATION	ISO 8573.1: 2010 CLASS
 <p>COMPRESSOR</p> <p>AFTER-COOLER</p> <p>MOISTURE SEPARATOR</p> <p>RECEIVER TANK</p> <p>EXTERNAL AUTO DRAIN</p>	 <p>COMPRESSED AIR FILTERS</p>	SIMPLE	2.-.2
	<p>AIR LINE DESIGN 2</p> <p>REFRIGERANT AIR DRYER</p>  <p>COMPRESSED AIR FILTERS</p> <p>COMPRESSED AIR FILTERS</p>	GENERAL PURPOSE	1.4.1
	<p>AIR LINE DESIGN 3</p> <p>REFRIGERANT AIR DRYER</p>  <p>COMPRESSED AIR FILTERS</p> <p>COMPRESSED AIR FILTERS</p>	ODORLESS	1.4.1
	<p>AIR LINE DESIGN 4</p>  <p>COMPRESSED AIR FILTERS</p> <p>DESICCANT DRYER</p> <p>COMPRESSED AIR FILTERS</p>	CRITICAL	<p>1.2.1 (-40 °C / -40°F)</p> <p>1.1.1 (-70 °C / -94 °F)</p>

Element Features

Mikropor offers Superior protection - from 1 micron to 0,01 micron. Durable element construction and efficient drain layer ensures continued performance with optimal element change intervals. Elements are also easy to replace with the plastic handles.

Mikropor Elements Have Been Designed for Easy Handling

- 1- Depth media construction offers higher coalescing performance.
- 2- Supreme collapse resistance due to usage of fluted stainless tube, providing strength against pressure drops while improving the performance by passing air diagonally through the element.
- 3- PVC impregnated foam favors water/oil drainage.



Element Advantages

- High energy efficiency due to low pressure drops
- Durability under high pressure conditions (20 bar)
- 4 different ranges of filtration efficiency which offers an opportunity to operate at various different filtration applications.
- High filtration capacity, which can target the smallest contaminants (0.01 micron and above) at 20 bar pressure.
- Minimization of valuable compressed air loss with Zero-Loss Drain option
- Third Party tested

Head Clamping

Head Clamping provides serial connection of filters without any extra piping, connection clamps are used for connecting multiple filters to each other. Wall mounting clamps are used to connect the filters to the wall easily.

Drainage Ribs

Drainage Ribs favors the humidity flow.

Correction Factor

For maximum flow rate of the filter model, multiply model flow rate shown in the below table by the correction factor corresponding to the working pressure.

Operating Pressure (bar)	PSI	Correction Factor
1	15	0.5
3	44	0.71
5	73	0.87
7	100	1
9	131	1.12
11	160	1.22
13	189	1.32
15	218	1.44
16	232	1.50
18	261	1.57
20	290	1.63

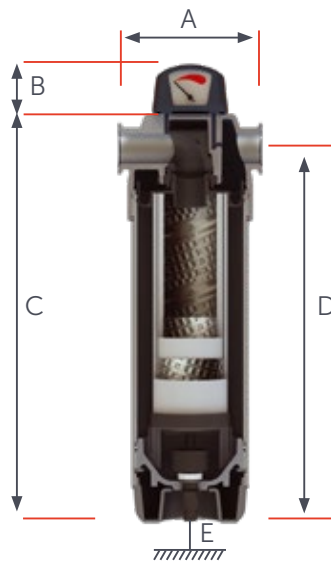

Zero Clearance

A major innovation for servicing the zero clearance design gives a quicker, easier, simpler filter change, with no need for any special tools.

Anodising

Anodising provides supreme corrosion resistance. Anodised surface treatment is proven to be better than other surface treatment methods such as Alocrome coating. Contact Mikropor to get comparison test results between competitor filters with Alocrome coating and Mikropor filters with anodising treatment.

Options

- Drains: Automatic / Manuel / Zero Loss
- Indicator or No indicator
- O-rings: Viton

Alternative Filters

- "S" Grade: Sterile Filter
- "H" Grade: Hopcalite Filter
- "T" Grade: 25 micron Coarse Dust Filter
- "HT" Grade: High Temperature Filters

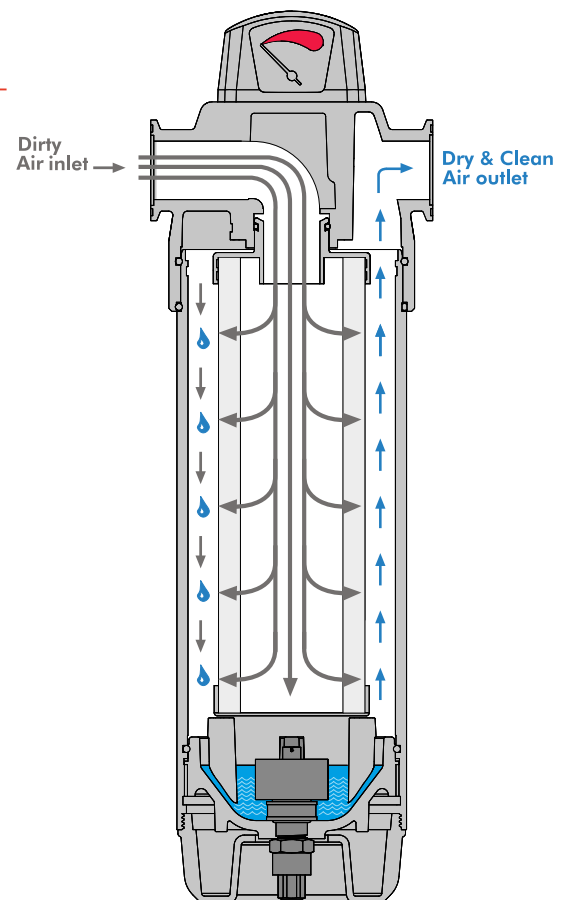

The reliability of GON Series is guaranteed by the results obtained from "Third Party Tests" which is renowned worldwide in the Compressed Air Industry.

Technical Specifications

Model	Connection Size			Flow Rate		Max. Working Pressure (bar)	Element Model	Housing Dimensions (mm)				
				(m³/h)	(cfm)			A	B	C	D	E
GON-35	1/4"	3/8"	1/2"	35	21	20	MON35	90	36,5	214	192	19
GON-55	1/4"	3/8"	1/2"	55	33	20	MON55	90	36,5	251,5	230	19
GON-70	3/8"	1/2"	-	70	42	20	MON70	128	45	273	249,5	32
GON-100	3/8"	1/2"	-	100	60	20	MON100	128	45	302,5	279	32
GON-125	3/8"	1/2"	-	125	75	20	MON125	128	45	343	319,5	32
GON-150	3/4"	1"	-	150	90	20	MON150	140	45	369	334,5	31
GON-225	3/4"	1"	-	225	135	20	MON225	140	45	398	364,5	31
GON-300	1 1/4"	1 1/2"	-	300	180	20	MON300	140	45	474	432	31
GON-400	1 1/4"	1 1/2"	-	400	240	20	MON400	140	45	564	522	31
GON-500	1 1/4"	1 1/2"	2"	500	300	20	MON500	151	45	511	464,5	25
GON-600	1 1/2"	1 1/2"	2"	600	360	20	MON600	151	45	626	579,5	25
GON-800	1 1/4"	1 1/2"	2"	800	480	20	MON800	151	45	696	649,5	25
GON-1000	1 1/4"	1 1/2"	2"	1000	600	20	MON1000	151	45	851	804,5	25
GON-1200	1 1/4"	1 1/2"	2"	1200	720	20	MON1200	151	45	976	929,5	25
GON-HC-1550	2 1/2"	3"	-	1550	930	20	MONHC1550	240	45	707	659,5	25
GON-HC-2000	2 1/2"	3"	-	2000	1200	20	MONHC2000	240	45	862	814,5	25
GON-HC-2700	2 1/2"	3"	-	2700	1620	20	MONHC2700	240	45	987	939,5	25
GO-HC-3400	DN100	-	-	3400	2040	16	MO3400	360	45	871	810	30
GO-HC-4500	DN100	-	-	4500	2700	16	MO4500	360	45	926	865	30
GO-HC-5400	DN100	-	-	5400	3240	16	MO5400	360	45	1070	1009	30

Specifications	Pre Filtering	General Purpose	Oil Removal	Activated Carbon	Indicator Type
Grade	P	X	Y	A	Differential Pressure Gauge
Particle Removal (Micron)	5	1	0.01	0.01	Drain Type
Max. Oil Carryover at 21°C (mg/m³)	5	0.5	0.01	0.003	
Max. Recommended Temperature (°C)	80	80	80	50	Electro-Adjustable
Initial Pressure Loss (mbar)	40	80	100	80	External Float Type
Pressure Loss for Element Change (mbar)	700	700	700	700	Zero-Loss Drain
Element Color Mode	White	White	White	Metal SS	Manual

For 0,003 mg/m³ quality oil in the air, the inlet temperature should be 25°C.

Notes

- 1) Given flows are at 7 barg pressure with reference to 20°C and 1 bar atmospheric air suction as per ISO 7183. In order to calculate the flow capacities at other pressures please refer to the correction factor table on page 9.
- 2) Grade A must not operate in oil saturated conditions.
- 3) Grades P, X and Y elements need to be replaced periodically to suit applications but must be changed at least every 8000 hours.
- 4) Grade A elements should be replaced periodically to suit the applications but must be changed at least every six months.
- 5) Grade A will not remove certain gases including carbon monoxide and carbon dioxide.
- 6) Flow rates are based on a 7 bar operating pressure, for flows at other pressures use correction factor given above.
- 7) All filters are suitable for use with mineral and synthetic oils.
- 8) Gauge type pressure indicators are fitted to all models as standard except Activated Carbon Filters.
- 9) All filters are in conformity with the 2014/68/EU Pressure Equipment Directive.

Ordering

The complete filter model number contains the size and grade, example – GON-150-1-X represents 150 m³/h capacity and 1" connection general purpose filter model with replacement filter element model X.



Features

- Elements are assembled with a tie rod system
- Two external float drains for maximum drainage
- Unique design for pre-separation zone
- Strong welded design
- CE and ASME tanks available
- Design for easy element change from top flange

External Float Drain

Mikropor external drain is designed to remove liquid condensation from collection points in a Compressed Air System.

Durable epoxy powder-coat finish and corrosion resistant internal anodised coating for longer service life.

Correction Factor

For maximum flow rate, multiply model flow rate show in the above table by the correction factor corresponding to the working pressure.

Operating Pressure (bar)	PSI	Correction Factor
1	15	0.5
3	44	0.71
5	73	0.87
7	100	1
9	131	1.12
11	160	1.22
13	189	1.32
14	200	1.38

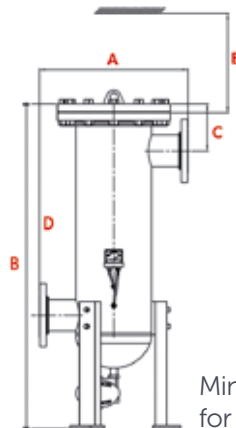

Minimum clearance for element change



Minimum clearance for element change

High Performance Elements Inside



Technical Specifications

Model	Drain Port Size	Inlet/Outlet Port Size	Flow Rate		Max. Working Pressure (bar)	Element Model	Number of Elements	Housing Dimensions (mm)				
			(m ³ /h)	(cfm)				A	B	C	D	E
F2500	1/2"	DN80	2500	1470	14	M1200	2	450	1287	277	747	650
F3200	1/2"	DN100	3200	1880	14	M1200	3	450	1317	277	767	650
F4300	1/2"	DN100	4300	2530	14	M1200	4	530	1344	279	769	650
F6500	1/2"	DN150	6500	3825	14	M1200	6	580	1425	331	796	650
F8500	1/2"	DN150	8500	5000	14	M1200	8	650	1439	333	798	650
F11000	1/2"	DN200	11000	6470	14	M1200	10	750	1504	365	825	650
F14000	1/2"	DN200	14000	8235	14	M1200	14	800	1545	383	833	650
F17000	1/2"	DN250	17000	10000	14	M1200	16	850	1583	417	862	650
F21000	1/2"	DN300	21000	12350	14	M1200	17	850	1680	447	887	650
F25500	1/2"	DN350	25500	15000	14	M1200	23	850	1778	487	917	650
F30000	1/2"	DN350	30000	17650	14	M1200	28	850	1778	487	917	650

Given flows are at 7 barg pressure with reference to 20°C and 1 bar atmospheric air suction as per ISO7183.

Specifications	Pre Filtering	General Purpose	Oil Removal	Activated Carbon	Drain Type
Grade	P	X	Y	A	Electro - Adjustable
Particle Removal (Micron)	5	1	0.01	0.01	External Float Type
Max. Oil Carryover at 21°C (mg/m ³)	5	0.5	0.01	0.003	Zero-loss Drain
Max. Working Temperature (°C)	80	80	80	50	Manual
Initial Pressure Loss (mbar)	40	80	100	80	
Pressure Loss for Element Change (mbar)	700	700	700	700	
Element Color Mode	White	White	White	Metal SS	

For 0,003mg/m³ quality oil in the air, the inlet temperature should be 25°C.

Notes

- Grade A must not operate in oil saturated conditions.
- Grade A elements should be replaced periodically to suit the applications but must be changed at least every six months.
- Grade A will not remove certain gases including carbon monoxide and carbon dioxide. Please refer to works if in doubt.
- Flow rates are based on a 7 bar operating pressure, for flows at other pressures use correction factor given above.
- All filters are suitable for use with mineral and synthetic oils.
- Other standards for flanged connections are available.
- Direction of air flow is inside to out, through filter element.

Ordering

The complete filter model number contains the size and grade, Example - pipe size NW100 oil removal filter with model filter F3200MY replacement filter element model M1200Y.

- Ultra low pressure drop reduces energy costs
- Positive gasket seals eliminate media bypass
- Filter change out differential 170 mbar (2.5 psi)
- True Air/Oil Separator
- Long service life

Applications Include

- Capturing oil fog, mist, or smoke from exhaust and pressure unloading vents on oil flooded compressors, vacuum pumps and blowers
- Any application requiring Low Delta P coalescing of large air volumes
- Vacuum Freeze Drying
- Vacuum Out-Gassing and Vacuum Coating
- Food Processing
- Nailers/Staplers
- Industrial Vacuum Processes
- Cement & Paper Processing

Design

Mist Eliminators are designed to meet the demand for:

- Efficient removal of oil-mist carryover from piston or oil flooded rotary compressors
- Long service life
- Protection from oil slugs or compressor Air/Oil separator failure

Features

- Very low pressure drop
- High oil removal efficiency
- Easy field changing
- Positive sealing O-rings
- Temperature (continuous) 4°C (40°F) min. 80°C (176°F) max.
- Auto Float Drain is standard
- Multiple drain style options available
- Pressure rating of 14 bar (200 psi)
- Removal of particles down to 0.01 micron including coalesced liquid water and oil, providing a maximum remaining oil aerosol content of 0.01 ppm
- Increased surface area in a given volume allows low velocity separation of ultra fine oil mist
- Elements are grounded to canister, minimizing static electricity problems

CARBOLESCER ELEMENT (Optional)

Combination of mist eliminator with Activated Carbon bed. Aerosols are coalesced by the mist eliminator down to 0.01 mg/m³ and oil vapor is absorbed by the Activated Carbon section down to 0.003 ppm. This allows Mikropor Carbolescer users to achieve oil free air even after oil flooded compressors.

Oil Indicator

Oil indicator is standard for all models with Carbolescer Element.

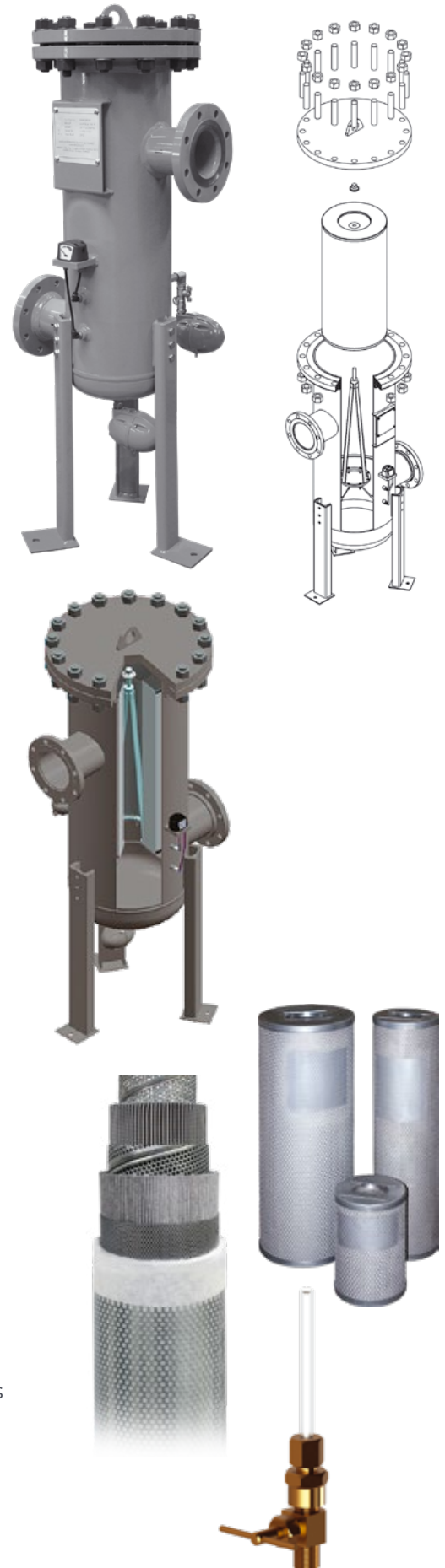

Correction Factor

For maximum flow rate, multiply model flow rate show in the above table by the correction factor corresponding to the working pressure.

Operating Pressure (bar)	PSI	Correction Factor
1	15	0.5
3	44	0.71
5	73	0.87
7	100	1
9	131	1.12
11	160	1.22
13	189	1.32
14	200	1.38

Drain Type
Electro - Adjustable
External Float Type
Zero-loss Drain
Manual

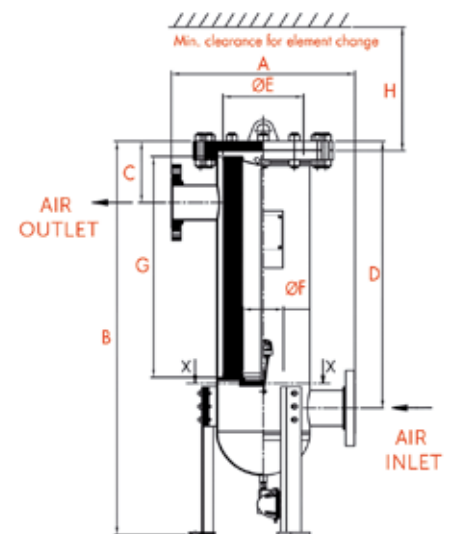
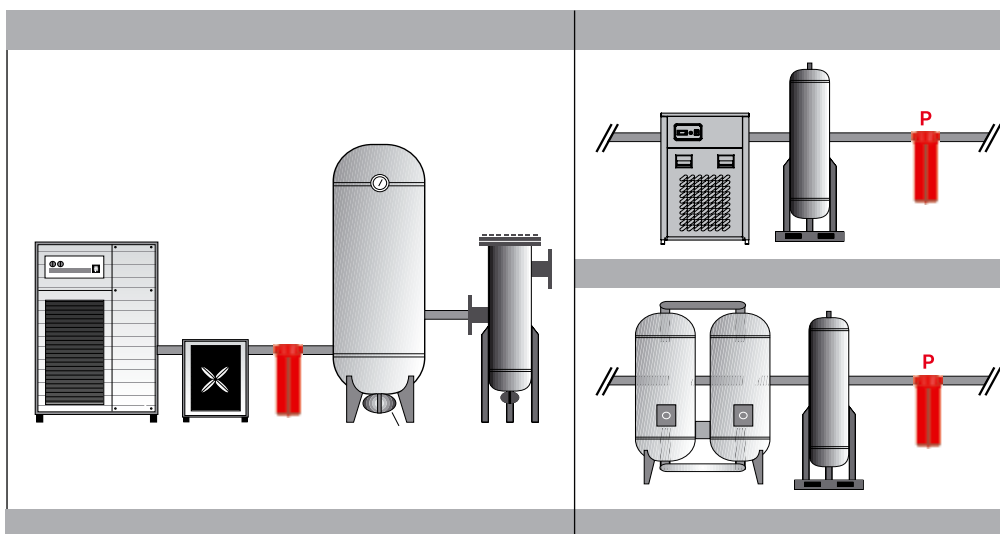

Technical Specifications

Model	Drain Port Size	Inlet/Outlet Port Size	Flow Rate		Max. Working Pressure (bar)	Housing Dimensions (mm)							
			(m³/h)	(cfm)		A	B	C	D	Ø E	Ø F	G	H
ELM-150	1/2"	DN50	255	150	14	500	1003	209	459	203	103	305	330
ELM-300	1/2"	DN50	510	300	14	500	1105	209	559	203	103	407	435
ELM-600	1/2"	DN50	1020	600	14	500	1461	209	916	203	103	762	790
ELM-800	1/2"	DN80	1360	800	14	500	1655	279	1084	203	103	915	950
ELM-1200	1/2"	DN80	2040	1200	14	500	1520	281	931	254	103	762	790
ELM-1600	1/2"	DN80	2720	1600	14	500	1671	281	1086	254	103	915	950
ELM-2100	1/2"	DN100	3570	2100	14	500	1575	335	953	300	129	762	790
ELM-2750	1/2"	DN100	4675	2750	14	500	1726	335	1100	300	129	915	950
ELM-4200	1/2"	DN150	7140	4200	14	500	1670	393	983	365	181	762	790
ELM-6000	1/2"	DN150	10200	6000	14	500	1925	393	1238	365	181	950	1045
ELM-8000	1/2"	DN200	13600	8000	14	500	2020	417	1277	386	233	1016	1045
ELM-10000	1/2"	DN250	17000	10000	14	500	2118	417	1307	407	337	1016	1045
ELM-12000	1/2"	DN300	20400	12000	14	500	2688	497	1847	437	337	1524	1550

Given flows are at 7 barg pressure with reference to 20°C and 1 bar atmospheric air suction as per ISO7183.

High Pressure & High Performance



Features

Mikropor manufactures a line of High Performance Compressed Air Filters, Moisture Separators in two different ranges; 50 bar range made of Aluminium. No welding, strong and reliable design. 350 bar range made of Steel. No welding and designed for reliability at very high pressure applications.

Anodised Aluminium Design with High Performance

Mikropor High Pressure Range Compressed Air Filters are NO-weld design. These Filters are built with ample wall thickness and as a result are extremely robust. In-house high pressure test facilities assure the performance. All inner and outer surfaces of 50 bar Aluminium design Filters are Anodised, where 350 bar Carbon Steel design Filters are epoxy electro powder coated.

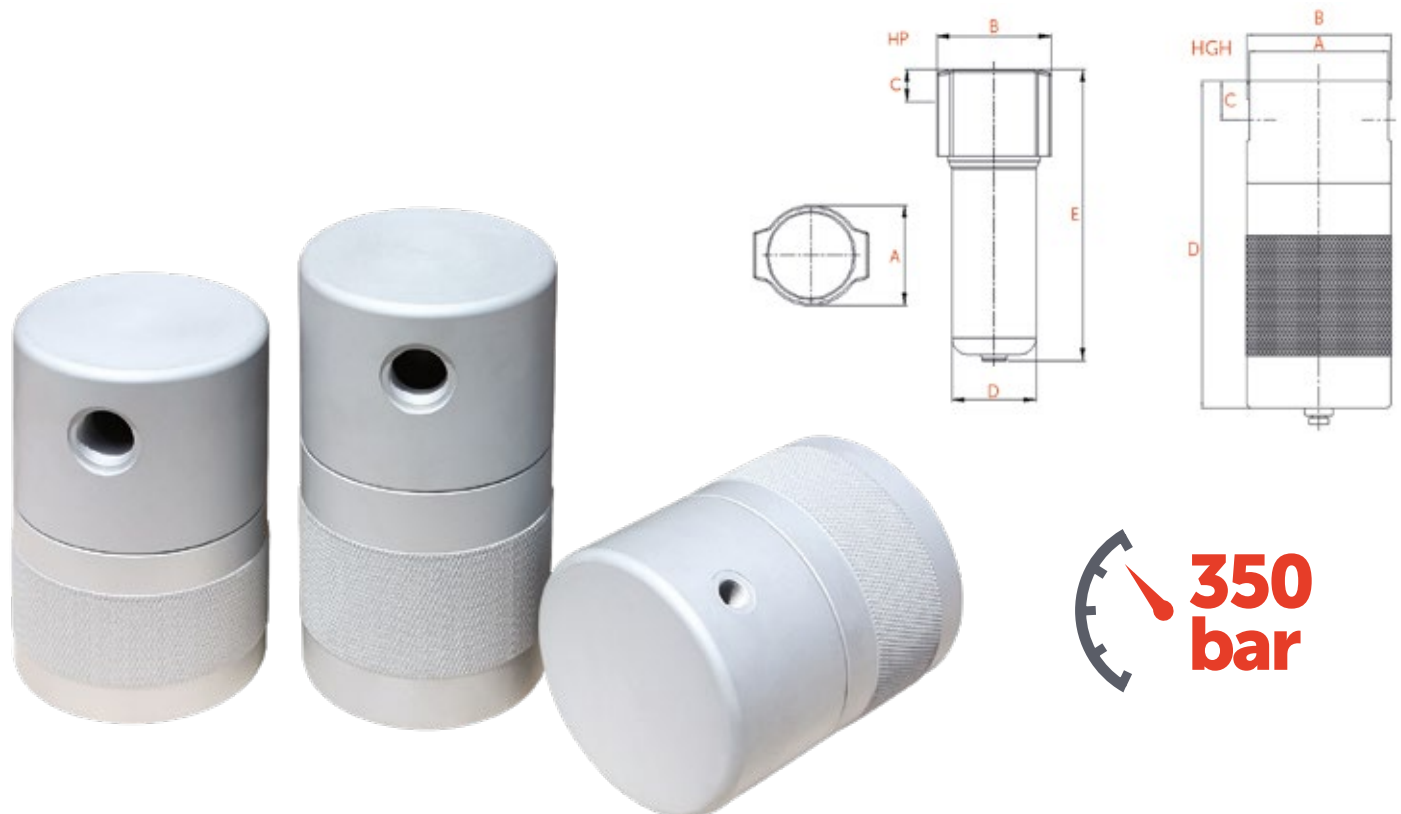

Technical Specifications

Model	Connection Size	Flow Rate at 50 bar		Max. Working Pressure (bar)	Element Model	Housing Dimensions (mm)				
		(m ³ /h)	(cfm)			A	B	C	D	E
HP100	1/4"	71	42	50	M25	106	119	30	88	201
HP300	1/2"	212	125	50	M50	106	119	30	88	201
HP600	3/4"	425	250	50	M100	106	119	30	88	201
HP850	1"	595	350	50	M150	123	140	39.5	103	357
HP1200	1"	850	500	50	M200	123	140	39.5	103	357
HP1600	1 1/2"	1600	940	50	M250	123	140	39.5	103	357
HP2500	2"	2500	1470	50	M2500	159	179	56	133	380
HP3000	2 1/2"	3000	1765	50	M3000	159	179	56	133	380

Model	Connection Size	Flow Rate at 350 bar		Max. Working Pressure (bar)	Element Model	Housing Dimensions (mm)			
		(m ³ /h)	(cfm)			A	B	C	D
HGH100	1/4"	102	60	350	M25	113.4	115.4	25.75	155
HGH300	1/2"	298	175	350	M50	113.4	115.4	25.75	158.5
HGH600	3/4"	595	350	350	M100	109.4	115.4	32.25	207
HGH850	1"	850	500	350	M150	133	138	37.35	250
HGH1200	1"	1190	700	350	M200	133	138	37.35	314
HGH1600	1 1/2"	2240	1317	350	M250	128	138	44.4	368
HGH2500	2"	3500	2058	350	M2500	145	158	51.5	393
HGH3000	2 1/2"	4200	2470	350	M3000	160	178	57.6	386

Specifications	Pre Filtering	General Purpose	Oil Removal	Activated Carbon	Drain Type
Grade	P	X	Y	A	HP - Manual Brass Drain
Particle Removal (Micron)	5	1	0.01	0.01	HGH - Manual Brass Drain
Max. Oil Carryover at 21°C (mg/m ³)	5	0.5	0.01	0.003	
Max. Working Temperature (°C)	80	80	80	50	
Initial Pressure Loss (mbar)	40	80	100	80	
Pressure Loss for Element Change (mbar)	700	700	700	700	
Element Color Mode	White	White	White	Metal SS	

For 0,003mg/m³ quality oil in the air, the inlet temperature should be 25°C

Notes

- 1) Grade A must not operate in oil saturated conditions.
- 2) Grade A elements should be replaced periodically to suit the applications but must be changed at least every six months.
- 3) Grade A will not remove certain gases including carbon monoxide and carbon dioxide.
- 4) Flow rates are based on 50 bar for HP and 350 bar for HGH filters.
- 5) All filters are suitable for use with mineral and synthetic oils.
- 6) Other standards for flanged connections are available.
- 7) Direction of air flow is inside to out, through filter element.

Ordering

The complete filter model number contains the size and grade, example – GON-150-1-X represents 150 m³/h capacity and 1" connection general purpose filter model with replacement filter element model X.

► MCC SERIES CATALYTIC CONVERTER

FILTRATION AND SEPARATION ◀

Oil-free compressors are seen as the ideal solution for any application that requires oil-free air. For this reason, the majority of compressed air users prefer to install an oil-free compressor in their system.

However, oil-free compressors are more costly than their oil lubricated counterparts and do not necessarily deliver truly oil-free compressed air. Like all compressors, oil-free compressors can deliver what they receive from the ambient air. In industrial environments the ambient air typically contains between 0.05 to 0.5 mg/m³ of oil (hydrocarbons). When this atmospheric (ambient) air is compressed to 7 bar, the oil concentration output level of the oil-free compressor increases to between 0.4 and 4 mg/m³. This could not be considered oil-free air and will be a problem for the site if oil-free air is a strict requirement.

Mikropor has a more cost-effective solution to minimise compromises in a compressed air system with the new MCC Catalytic Converter. The MCC eliminates residual oil in compressed air by means of a catalytic reaction between the oil-laden air and the reactant (catalyst).

Mikropor's Catalytic Converters use a process of catalytic oxidation to actively transform the oil and hydrocarbons in compressed air and convert them to H₂O and CO₂ by utilizing a special type of catalyst.

Mikropor is delighted to present MCC which can be used as a perfect technical solution to obtain an oil-free compressed air system for a wide variety of industries. MCC Catalytic Converters deliver Class 0 oil-free compressed air in accordance with the ISO 8573-1 International Standard.

Oil content in compressor outlet air is reduced to less than **0.0025 mg/m³** by using heat-reactivated catalyst.

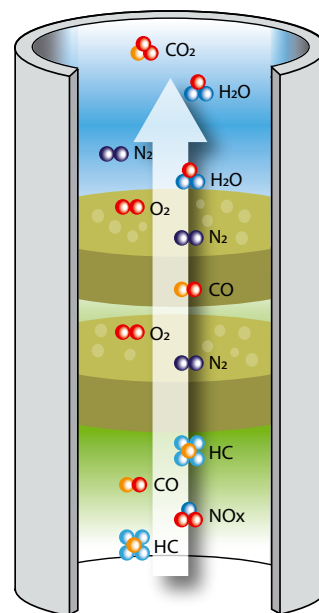

The clean exhaust exits the converter

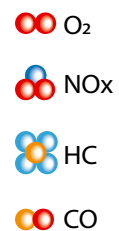
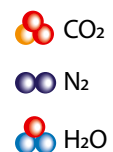

With the effect of exhaust gases entering the catalyst, oxidation of carbon monoxide (CO) and unburned Hydrocarbons (HC) and reduction of Nitrogen oxides (NO_x) occurs



Advantages

Mikropor’s MCC Catalytic Converters have less investment & operating cost compared to oil-free compressors and provide;

- Cost reductions (By investing in an oil-flooded compressor with an MCC rather than using an oil-free compressor)
- Maintenance cost reductions
- Extended filter change periods
- Eliminated additional costs for separating oil condensate
- Avoidance of costly production standby and shutdown.
- Consistent air quality which will remain at the same level for the lifetime of the catalyst
- Extended service life of downstream equipment
- Reduced energy consumption (maximum 0.01 kWh/m³ at maximum load)

Technical Structure Of MCC Series Catalytic Converter

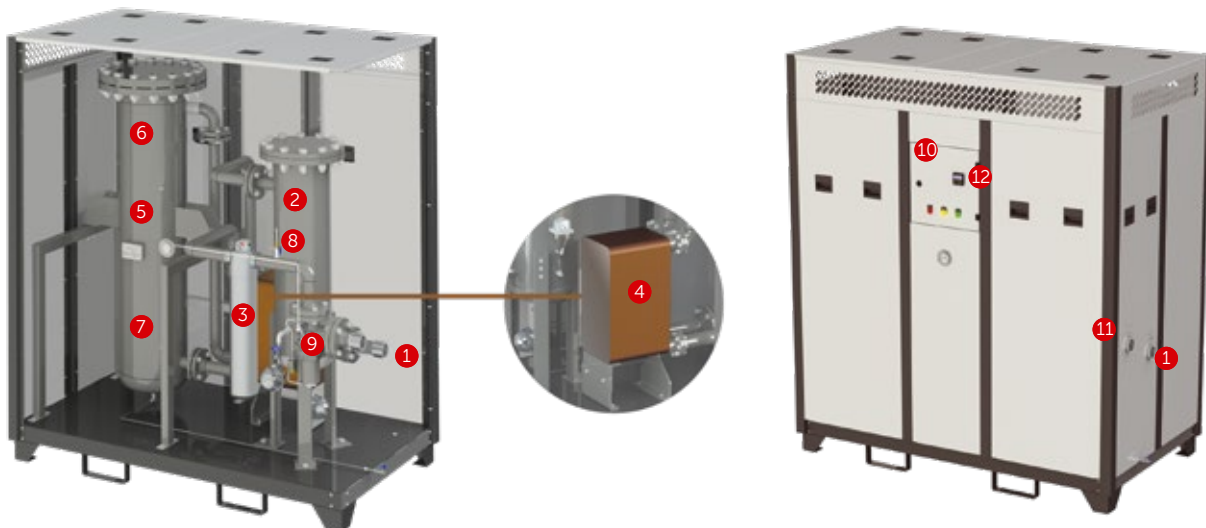

- | | |
|--|--------------------------------------|
| 1. Compressed Air Containing Oil From Compressor | 7. Catalyst (Inside the Tank) |
| 2. Mist Eliminator | 8. Oil Indicator |
| 3. Particulate Filter | 9. Minimum Pressure Closing Valve |
| 4. Heat Exchanger | 10. Electrical Enclosure |
| 5. Converter Vessel | 11. Oil-Free Compressed Air to Dryer |
| 6. Heater (Inside the Tank) | 12. Controller User Screen |

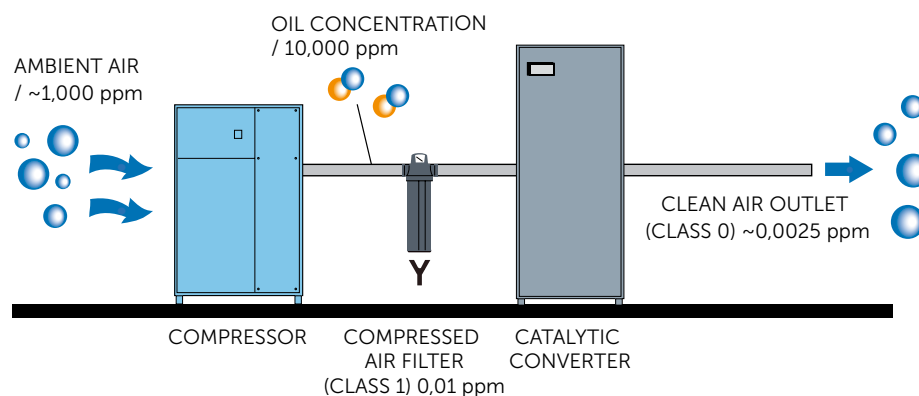

Basic Working Principle of MCC Series Catalytic Converter

At the first stage, specially designed catalyst in MCC vessels is heated up to a certain temperature. The oily inlet air gets resolved into hydrocarbons when entering the heated up container. These hydrocarbons are converted into water and carbon dioxide by reacting with oxygen molecules on the catalyst surface. Thereafter, completely oil free Class 0 compressed air gets cooled by a heat exchanger and delivered right into the system without the need for any additional treatment.



Oil Indicator

Most users would like to be sure that they deliver oil free compressed air to their processes. The oil indicator which is standard on MCC Catalytic Converters prove that there is no oil in the compressed air after the MCC Catalytic Converter.

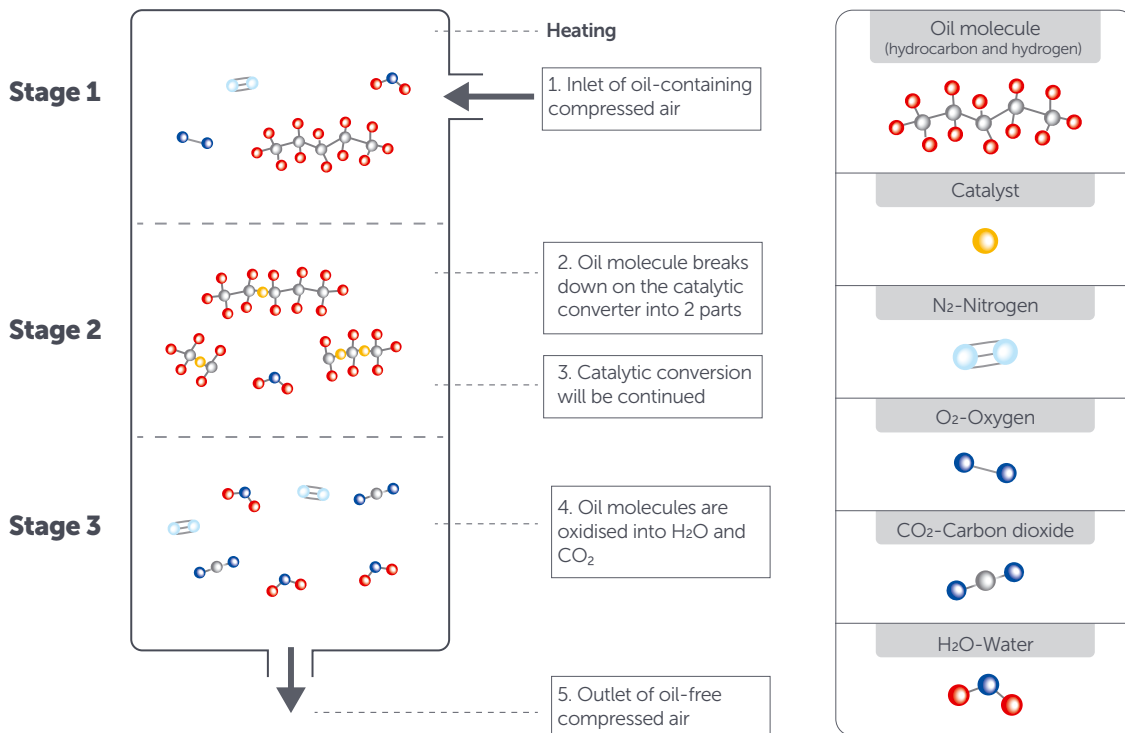

Components are Needed to Design an Oil-Free Class 0 Compressed Air System

CATALYTIC CONVERTER AIR LINE

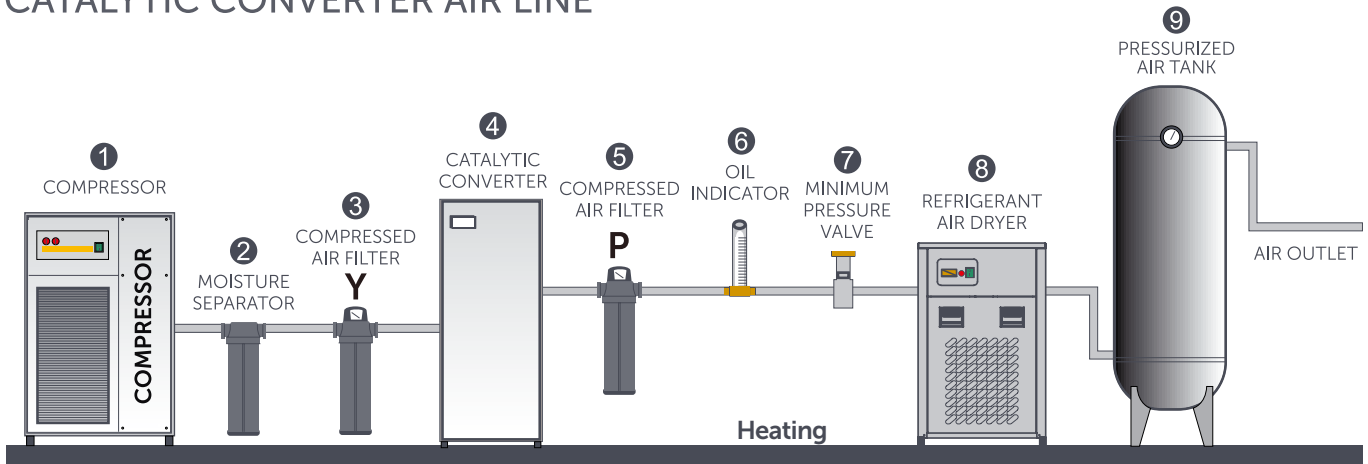

- 1- Compressor
- 2- Moisture Separator (Standard)
- 3- Compressed Air Filter-Y (Standard)
- 4- Catalytic Converter
- 5- Compressed Air Filter-P (Standard)
- 6- Oil Indicator
- 7- Minimum Pressure Valve (Standard)
- 8- Refrigerant Air Dryer
- 9- Pressurized Air Tank

Technical Specifications

Model	Air Capacity (Nm ³ /min)	Connection Size	Max. Working Pressure (bar)	Pressure Drop (mbar)	Voltage	Total Installed Power (kw)
MCC 11	1	1/2"	16	≤ 400	230/1/50-60	1,2
MCC 22	2	3/4"	16	≤ 400	230/1/50-60	2,5
MCC 55	5	1 1/4"	16	≤ 400	400/3/50-60	5
MCC 75	7	1 1/2"	16	≤ 400	400/3/50-60	5
MCC 110	10	1 1/2"	16	≤ 400	400/3/50-60	10
MCC 160	15	2"	16	≤ 400	400/3/50-60	10
MCC 210	20	2 1/2"	16	≤ 400	400/3/50-60	15
MCC 330	30	2 1/2"	16	≤ 400	400/3/50-60	21
MCC 430	43	DN 80	16	≤ 400	400/3/50-60	28
MCC 650	65	DN 100	16	≤ 400	400/3/50-60	28

03

COMPRESSED AIR DRYERS

MKE SERIES NON CYCLING INTEGRATED FILTRATION	38
ICE SERIES ICE CUBE / STATIC	44
MH SERIES HIGH TEMPERATURE	45
MCY SERIES THERMAL MASS/CYCLING INTEGRATED FILTRATION	46
MK-DS SERIES DIGITAL SCROLL INTEGRATED FILTRATION	52
MK-HP SERIES HIGH PRESSURE	56
ISO STANDARDS	59
MMD SERIES MODULAR DESICCANT	60
MDA SERIES HEATLESS DESICCANT	62
MBP SERIES HEATED DESICCANT	65

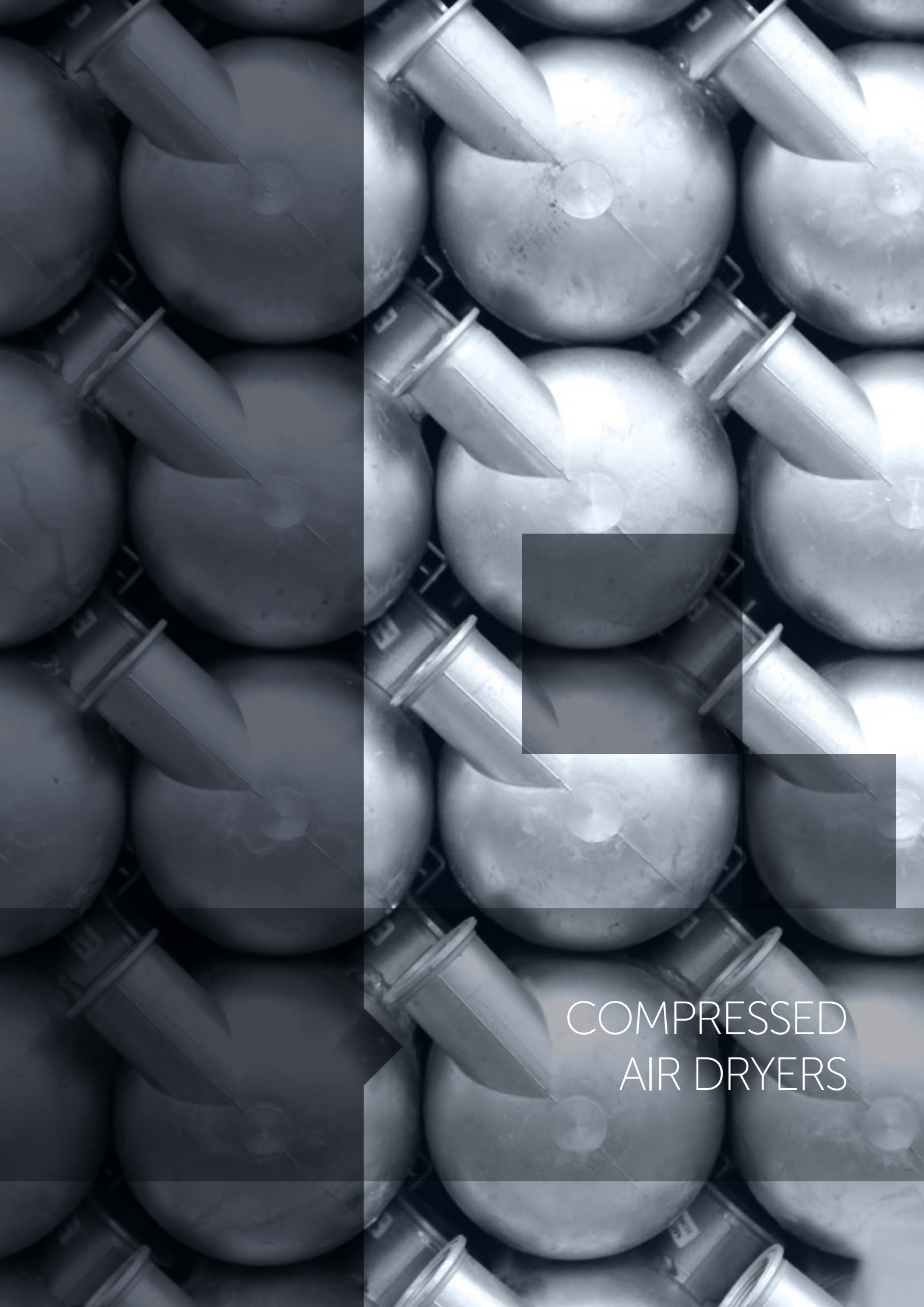

COMPRESSED
AIR DRYERS

► MKE SERIES NON CYCLING INTEGRATED FILTRATION

COMPRESSED AIR DRYERS ◀

Mikropor is aware of the importance of high quality compressed air and guarantees to provide customers with the highest quality of air. Using clean, dry air is extremely important for all kinds of air powered applications. Moisture or contamination in the air which will come from the standard compressor outlet will cause complicated system errors. These complications will decrease productivity and may affect the production quality of final products.

Advantages

- Low pressure drop saves compressor power
- Quick start and reaction time provides additional production time
- Every dryer is specially designed with the right components to consume the lowest energy
- Highly energy efficient and environmentally friendly R134a refrigerant across all models.
- R513a refrigerant is optional.
- A state-of-the-art heat exchanger design provides the highest cost saving in the industry
- Best in class refrigerant compressors consume less energy against competition dryers
- Pressure switches control the condenser's fan motor for saving energy and letting the system operate at desired conditions
- This is not only a dryer, but an air treatment package that delivers an air quality of class 1.4.1 as per ISO 8573:2010 due to integrated filtration

Applications

Mikropor provides an entire range of products for filtration and air purification applications at a cost effective price.

Applications Include

Food production, dairies, breweries, clean conveying air, chemical plants, pure air and cleanroom technology, pharmaceutical industry, weaving machines, photo labs, paint spraying, powder coating, packaging, control and instrument air, sand and/or shot blasting, general air works, microchip production, optics, process air as well as many other markets.

The MKE Series Refrigerant Circuit and Insulation

Mikropor only uses environmentally friendly R134a refrigerant gas in the dryers. This refrigerant is suitable for both low and high temperature applications. R-134a has excellent thermodynamic properties and can operate at very low pressure compared to other refrigerants. This will in turn increase the refrigerant compressor's service life. With R-134a Mikropor dryers can operate at very high ambient temperatures. Mikropor engineers add extra power to the heat exchangers with excellent and extraordinary no loss insulation system. Mikropor dryers supply constant dew point at all flow ranges. This perfect insulation idea continues on the refrigeration circuit side as well. With this insulation concept and oversized condensers (Even for ultra-high ambient temperatures) Mikropor Refrigerated Air Dryers offer the highest technology with its custom solutions.



Digital Controllers

Digi-Pro digital controller is standard on MKE23-MKE3915

ESD digital controller is standard on MKE5085-MKE12500

Digi-Pro Digital Controller

Mikropor now produces a new generation of air dryers with Digi-Pro series controllers. With the Digi-Pro series controllers, air dryers have outstanding technology for both functionality and dynamism, as well as appearance. New controller design offers users the possibility of making adjustments with one finger, thus easier accessibility. The touch keys have taken the design and dynamism to a top level of technology. The multi-functional display provides an accurate digital dew point display as well as coded alarm monitoring of the refrigerant dryer.

Digital controller with embedded features,

- Digital dew point monitoring
- Energy-saving mode display
- Periodic maintenance interval display
- Status report
- Hours run meter
- Fahrenheit and Centigrade selection

ESD Digital Controller

Mikropor Refrigerated Air dryers with ESD Digital controller have a lot of economy features and alarm capabilities. Refrigeration dryers are usually the most efficient dryer solution for the compressed air applications. With the help of the highly engineered ESD, Mikropor Refrigerated Air Dryers will reduce your energy consumption. ESD helps the service technicians to monitor many useful parameters on the dryer and guides them to troubleshoot any problem very easily. ESD is extremely useful when there is no air coming into the dryer when the dryer is running. Especially during the nights, weekends and holidays many companies do not stop their dryers although they do not run compressed air. ESD saves huge amount of money by simply shutting the dryer down automatically when it is not in use.



Electrical Wires are Separated From Refrigerant Side

There are very few electrical wires inside the refrigerant side of the dryer. Electrical box has an external cover with access from the outside of the dryer. Therefore there is no need to open dryer panels electrical access.

Compact Design

Mikropor dryers are highly reliable, efficient and have small space demands and offer low cost ownership. Mikropor Refrigerated Air Dryers are suitable for the smallest installation spaces. Having two filters integrated into the dryer frame offers a huge advantage to the service technicians and end users. The integrated filters save labor time, piping cost and space at the facilities where the Mikropor Dryer is used. The compact size also offers flexibility and economy during their transport.

Aluminium Plate Heat Exchanger is Standard

- Very low pressure drop
- Thin aluminium plate thickness
- High heat transfer surface area
- Strong due to external thick cylindrical wall
- Water separator is optimized for best performance

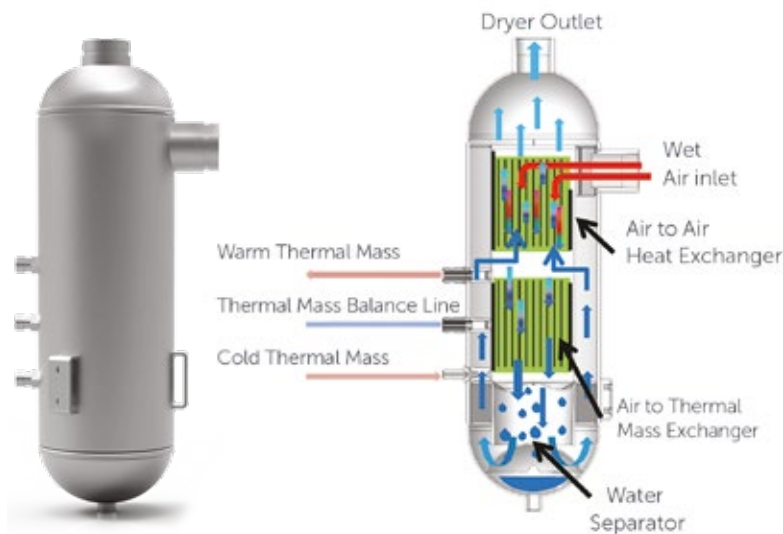

Scroll Compressors

Scroll Compressors are energy efficient and strong against liquid shocks. For energy saving, scroll compressors are used for 400 m³/h and above MKE Dryers.

Easy Access

Easy access to the cooling components in seconds by the help of screw free panels and plastic handles. Easy for service and offers more working space. Service technicians save time by not having to remove fasteners.



▶ **MKE SERIES** NON CYCLING INTEGRATED FILTRATION

COMPRESSED AIR DRYERS ◀

Zero Clearance Compressed Air Filters with High Performance Elements

Compressed Air Filter kit is standard on the Mikropor Dryers. The filter with X Element (coalescing filter for water removal) is used for up to 1 micron particles and the Filter with Y Element (coalescing filter for oil removal) is used to remove oil down to 0.01 ppm. Zero clearance design helps service technicians to replace the element in minutes. Mikropor Refrigerated Air Dryers are designed by engineers who have received all of the design feedback from field engineers and service technicians. This service friendly design makes Mikropor dryers very unique in the industry. Dryer Filter kit which has two elements, two automatic drains and two viton o-rings helps the customers to operate the dryer at its best performance until the next planned maintenance. Replacing drains on the filters is critical when replacing elements because drains will get clogged with dirt and oil over time.

Grooved Couplings and Fittings

On compressed air lines, grooved couplings and fittings are commonly used in the industry. These couplings increase flexibility on connections, help the service technician to dismantle and assemble pipes easily and quickly.

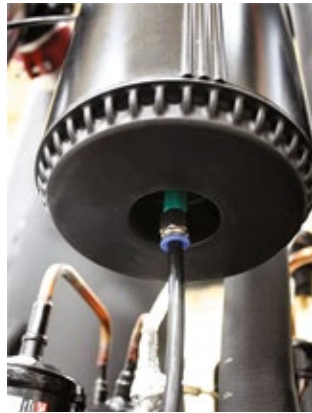

Excessive Water Droplet Drains

Liquid water droplets coming from the line to the inlet of the dryer are separated by the inlet filter and drained. Filter auto drains have manual valves on them. This allows the system to be depressurized when these filters go to service.



Replacement Filter Element

Pressure drop is a huge concern in compressed air. In many applications high pressure drops will cause a decrease in the pressure at the point of use. Sometimes this low pressure is not enough for the machines or processes to perform correctly. In addition, dirt particles and oil in the compressed air system may block the filters quickly. It is important for the end users and service technicians to recognize if there is a problem in the system. The performance of the filters directly affects the pressure drop and system performance. Therefore, it is very important that the filter elements are changed at the filter service time. An alarm/warning indicating that the filters are changed periodically is provided by a digital controller on the Mikropor Air Dryer. When this alarm triggers, the filter must be changed to avoid loss of performance and pressure drop.



Correction Factor for MKE Series

Inlet Temperature (°C)	F1	Ambient Temperature (°C)	F2	Pressure (bar)	F3
30	1,29	20	1,05	4	0,80
35	1	25	1	6	0,94
40	0,92	30	0,98	7	1
45	0,78	35	0,93	8	1,04
50	0,65	40	0,84	10	1,11
-	-	45	0,76	12	1,16
-	-	-	-	14	1,22
-	-	-	-	16	1,25

Example for Choosing the Correct Dryer;

If a compressor delivers 200 m³/h at 6 bar the dryer inlet temperature is 40°C and ambient temperature is 30°C

Please choose your Dryer as follows;

$$200 / 0.94 / 0.92 / 0.98 = 236 \text{ m}^3/\text{h}$$

The correct dryer for this application is MKE305

Nominal Working Pressure	7 barg	Minimum Inlet Temperature	5°C
Maximum Working Pressure	16 barg	Nominal Ambient Temperature	25°C
Minimum Working Pressure	4 barg	Maximum Ambient Temperature	45°C
Nominal Inlet Temperature	35°C	Minimum Ambient Temperature	5°C
Maximum Inlet Temperature	50°C	Refrigerant	R134a

Technical Specifications

Model	Capacity (m ³ /h)	Voltage	Connection Size	Filter Quantity and Type	Element Type	Pressure Drop (mbar)	Control Type	Dimensions		
								Length (mm)	Width (mm)	Height (mm)
MKE-23	23	230V / 1 Ph / 50 Hz	1/2"	1*GKON55X + 1*GKON55Y	MKON55 KIT	95	Digi-Pro	372	369	706
MKE-38	38	230V / 1 Ph / 50 Hz	1/2"	1*GKON55X + 1*GKON55Y	MKON55 KIT	150	Digi-Pro	372	369	706
MKE-53	53	230V / 1 Ph / 50 Hz	1/2"	1*GKON55X + 1*GKON55Y	MKON55 KIT	250	Digi-Pro	372	369	706
MKE-70	70	230V / 1 Ph / 50 Hz	1/2"	1*GKON75X + 1*GKON75Y	MKON75 KIT	220	Digi-Pro	372	369	706
MKE-100	100	230V / 1 Ph / 50 Hz	3/4"	1*GKON155X + 1*GKON155Y	MKON155 KIT	80	Digi-Pro	454	473	832
MKE-155	155	230V / 1 Ph / 50 Hz	3/4"	1*GKON155X + 1*GKON155Y	MKON155 KIT	195	Digi-Pro	453	473	832
MKE-190	190	230V / 1 Ph / 50 Hz	3/4"	1*GKON155X + 1*GKON155Y	MKON155 KIT	290	Digi-Pro	453	473	832
MKE-210	210	230V / 1 Ph / 50 Hz	1 1/2"	1*GKON405X + 1*GKON405Y	MKON405 KIT	195	Digi-Pro	506	556	875
MKE-305	305	230V / 1 Ph / 50 Hz	1 1/2"	1*GKON405X + 1*GKON405Y	MKON405 KIT	290	Digi-Pro	506	556	875
MKE-375	375	230V / 1 Ph / 50 Hz	1 1/2"	1*GKON405X + 1*GKON405Y	MKON405 KIT	180	Digi-Pro	506	556	875
MKE-495	495	230V / 1 Ph / 50 Hz	2"	1*GKON805X + 1*GKON805Y	MKON805 KIT	280	Digi-Pro	648	678	1157
MKE-623	623	230V / 1 Ph / 50 Hz	2"	1*GKON805X + 1*GKON805Y	MKON805 KIT	210	Digi-Pro	648	678	1157
MKE-930	930	230V / 1 Ph / 50 Hz	2"	1*GKON1205X + 1*GKON1205Y	MKON1205 KIT	130	Digi-Pro	947	727	1369
MKE-1200	1200	230V / 1 Ph / 50 Hz	2"	1*GKON1205X + 1*GKON1205Y	MKON1205 KIT	160	Digi-Pro	947	727	1369
MKE-1388	1388	400V / 3 Ph / 50 Hz	3"	1*GKON-HC-1805X + 1*GKON-HC-1805Y	MKON-HC-1805 KIT	320	Digi-Pro	948	798	1459
MKE-1800	1800	400V / 3 Ph / 50 Hz	3"	1*GKON-HC-1805X + 1*GKON-HC-1805Y	MKON-HC-1805 KIT	260	Digi-Pro	948	798	1459
MKE-2500	2500	400V / 3 Ph / 50 Hz	3"	1*GKON-HC-2775X + 1*GKON-HC-2775Y	MKON-HC-2775 KIT	170	Digi-Pro	1163	778	1722
MKE-2775	2775	400V / 3 Ph / 50 Hz	3"	1*GKON-HC-2775X + 1*GKON-HC-2775Y	MKON-HC-2775 KIT	320	Digi-Pro	1163	778	1722
MKE-3330	3330	400V / 3 Ph / 50 Hz	DN100 Flange	1*GKO5850X + 1*GKO5850Y	GKO5850 KIT	240	Digi-Pro	1577	993	1906
MKE-3915	3915	400V / 3 Ph / 50 Hz	DN100 Flange	1*GKO5850X + 1*GKO5850Y	GKO5850 KIT	350	Digi-Pro	1577	993	1906
MKE-5085	5085	400V / 3 Ph / 50 Hz	DN100 Flange	1*GKO5850X + 1*GKO5850Y	GKO5850 KIT	295	ESD-3	1647	1077	2005
MKE-5850	5850	400V / 3 Ph / 50 Hz	DN100 Flange	1*GKO5850X + 1*GKO5850Y	GKO5850 KIT	320	ESD-3	1647	1077	2005
MKE-6975	6875	400V / 3 Ph / 50 Hz	DN150 Flange	** Externally Connected - F6500 X / Y	6*M1200 KIT	295	ESD-3	2188	1062	2024
MKE-7875	7875	400V / 3 Ph / 50 Hz	DN150 Flange	** Externally Connected - F8500 X / Y	8*M1200 KIT	320	ESD-3	2188	1062	2024
MKE-9000	9000	400V / 3 Ph / 50 Hz	DN150 Flange	** Externally Connected - F11000 X / Y	10*M1200 KIT	320	ESD-3	2247	1200	2044
MKE-10500	10500	400V / 3 Ph / 50 Hz	DN200 Flange	** Externally Connected - F11000 X / Y	10*M1200 KIT	320	ESD-3	2247	1200	2044
MKE-12500	12500	400V / 3 Ph / 50 Hz	DN200 Flange	** Externally Connected - F14000 X / Y	14*M1200 KIT	320	ESD-3	2550	1550	2100

Note: Water condenser is available for all models

Given flows are at 7 barg pressure with reference to 20°C and 1 bar atmospheric air suction as per ISO7183.

** Not integrated and not included in standard package.

Static Air Dryers

Ice Cube Dryers have static condensers without a cooling fan. Therefore they are energy efficient with low noise level and compact design. Ice Cube Dryers also have long service life and low maintenance needs.

Advantages

- Superior energy saving due to static condenser
- Efficient refrigerant compressor with low pressure drop
- +7°C dew point
- No condenser blockage due to wide condenser design
- Standard expansion valve
- 3-in-1 heat exchanger design (air/air - air/refrigerant - water separator in one block)
- Easy to service auto-drain
- High pressure switch
- No loss of compressed air (Zero Loss)
- Less refrigerant gas used than equivalents, environmentally friendly

Applications

Ideal for hospitals and laboratories with compact design and low noise needs. Ice Cube Dryers are also suitable for other applications which need dry air with a low price.



Model	Capacity (m³/h)	Voltage	Connection Size	Absorbed Power (kW)	Max. Amp. (A)	Fuse Amp. (A)	Pressure Drop (mbar)	Dimensions (mm)			Weight
								Width	Length	Height	
IC-50	50	230V / 1 Ph / 50 Hz	1/2"	0,28	2,98	4	140	366	366	521	21
IC-70	70	230V / 1 Ph / 50 Hz	1/2"	0,31	2,08	4	170	366	366	521	23
IC-100	100	230V / 1 Ph / 50 Hz	1/2"	0,43	4,8	8	200	366	366	521	25
IC-130	130	230V / 1 Ph / 50 Hz	3/4"	0,56	4,8	8	180	366	366	758	34

Correction Factor for IC Series

Required Flow / F1 / F2 / F3 = Corrected Flow

Inlet Temperature (°C)	F1	Ambient Temperature (°C)	F2	Pressure (bar)	F3
30	1,29	20	1,05	4	0,80
35	1	25	1	6	0,94
40	0,92	30	0,98	7	1
45	0,78	35	0,93	8	1,04
50	0,65	40	0,84	10	1,11
-	-	43	0,81	12	1,16
-	-	-	-	14	1,22
-	-	-	-	16	1,25

Nominal Working Pressure	7 barg	Minimum Inlet Temperature	5°C
Maximum Working Pressure	16 barg	Nominal Ambient Temperature	25°C
Minimum Working Pressure	4 barg	Maximum Ambient Temperature	43°C
Nominal Inlet Temperature	35°C	Minimum Ambient Temperature	5°C
Maximum Inlet Temperature	50°C	Refrigerant	R134a

Aluminium Plate Heat Exchanger

- High heat transfer surface area
- Strong due to thick external wall
- Low pressure drop
- Water Separator is optimized for best performance

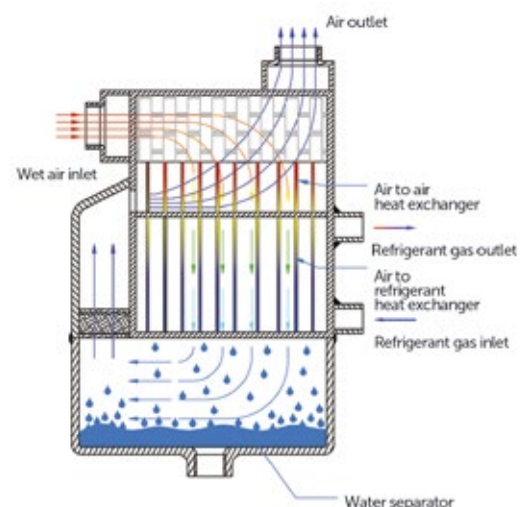

Given flows are at 7 barg pressure with reference to 20°C and 1 bar atmospheric air suction as per ISO7183.

► MH SERIES HIGH TEMPERATURE

COMPRESSED AIR DRYERS ◀

Most compressor manufacturers do not use an aftercooler on their piston type compressors. Therefore compressed air exits the compressor at about 100°C temperature. Mikropor's High Temperature Dryer has an aftercooler to reduce the inlet temperature.

After Cooler Condenser Inside

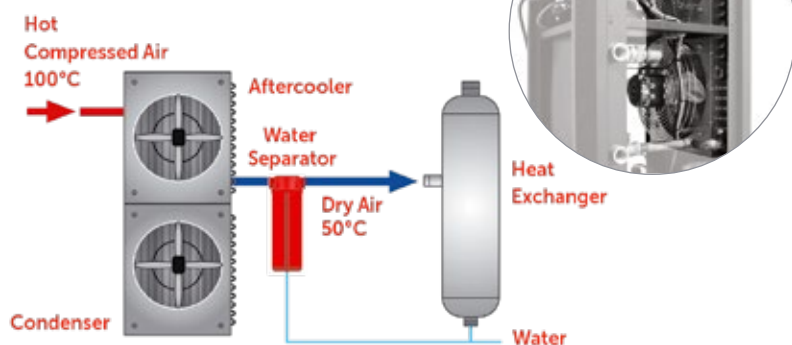

Technical Specifications

Model	Capacity (m ³ /h)	Voltage	Connection Size	Dimensions (mm)		
				Width	Length	Height
MH-31	31	230V / 1 Ph / 50 Hz	1/2"	447	448	957
MH-52	52	230V / 1 Ph / 50 Hz	1/2"	447	448	957
MH-75	75	230V / 1 Ph / 50 Hz	1/2"	447	448	957
MH-106	106	230V / 1 Ph / 50 Hz	3/4"	447	448	957
MH-160	160	230V / 1 Ph / 50 Hz	3/4"	512	627	877
MH-212	212	230V / 1 Ph / 50 Hz	3/4"	512	627	877

Correction Factor for MH Series

Required Flow / F1 / F2 / F3 / F4 = Corrected Flow

Pressure (bar)	F1	Inlet Temperature (°C)	F2	Ambient Temperature (°C)	F3	Dew Point (°C)	F4
4,1	0,70	4	1,40	4	1,10	3,3	0,65
5	0,75	10	1,40	10	1,10	5	0,73
6	0,80	16	1,40	16	1,10	7,2	0,80
7	0,83	21	1,40	24	1,10	10	1
7,9	0,86	26	1,35	29	1,07	12,8	1,10
8,5	0,90	32	1,30	35	1,03	15,5	1,22
10	0,93	38	1,27	38	1	-	-
11	0,96	65	1,06	40	0,96	-	-
12	1	82	1	45	0,82	-	-
13	1,10	93	0,85	-	-	-	-
14	1,12	98	0,78	-	-	-	-
16	1,15	104	0,75	-	-	-	-

Nominal Working Pressure	12 barg	Minimum Inlet Temperature	5°C
Maximum Working Pressure	16 barg	Nominal Ambient Temperature	38°C
Minimum Working Pressure	4 barg	Maximum Ambient Temperature	43°C
Nominal Inlet Temperature	82°C	Minimum Ambient Temperature	5°C
Maximum Inlet Temperature	104°C	Refrigerant	R134a

Given flows are at 7 barg pressure with reference to 20°C and 1 bar atmospheric air suction as per ISO7183.

▶ **MCY SERIES THERMAL MASS/CYCLING INTEGRATED FILTRATION**



COMPRESSED AIR DRYERS ◀

Mikropor Air Quality Focus

Mikropor knows the importance of high-quality compressed air and provides customers with the highest quality air possible. Using clean, dry air is extremely important for most air powered applications. Moisture or contamination in the air from the compressor discharge will result in many complications to production equipment. These complications will decrease productivity and may affect the production quality of final product.

Applications

Mikropor provides an entire range of products for filtration and air purification applications to fit various market requirements (ISO 8573.1: 2010 standard). Applications include: Food production, dairies, breweries, chemical plants, pure air and clean room technology, pharmaceutical industry, weaving machines, photo labs, paint spraying, powder coating, packaging, control and instrument air, sand and / or shot blasting, general air works, microchip production, optics, process air as well as many other industries.



International
Organization for
Standardization



The Refrigerant Circuit and Insulation

Mikropor exclusively uses environmentally friendly R134a refrigerant gas in the dryers. This refrigerant is suitable for both low and high temperature applications. R-134a has excellent thermodynamic properties and can operate at very low pressure compared to other refrigerants. This will in turn increase the refrigerant compressor's service life. With R-134a Mikropor dryers can operate at very high ambient temperatures. Mikropor engineers add extra capability to the heat exchangers with a superior no loss insulation system. This perfect insulation philosophy continues to the refrigeration circuit side also. Superior insulation and oversized condensers (for ultra-high ambient temperatures) enable the MCY Series Dryers to offer continuous air quality.

Mikropor MCY Series Cycling air dryers supply constant dewpoint at all flow ranges.



▶ MCY SERIES THERMAL MASS/CYCLING INTEGRATED FILTRATION



COMPRESSED AIR DRYERS ◀

Compact Design

MCY Series Air Dryers are highly reliable, efficient, have small space requirements and offer low cost ownership. Integration of pre / post filtration within the dryer cabinet saves labor time, installation cost and valued production space. The compact size also offers flexibility and economy during transportation.

SAFETY - Electrical Cabinet Isolation

- Electrical panel separated from service areas of the dryer.
- Minimization of electrical components from refrigerant side of dryer.
- Electrical controls access without exposure high heat areas.



MCY Advantage

- Best-in-class low package pressure drop saves energy consumption from the supplying air compressor.
- Thermal mass technology offers stable pressure dewpoint at varying loads.
- Mikropor state of the art "3 in 1" cast aluminium heat exchanger provides unmatched longevity & cooling.
- Glycol cooling components are all stainless steel. 65°C Max inlet temp.



Mikropor Advanced "3 in 1" Heat Exchanger

Thermally Optimized Encapsulated Design

- Air to Air Exchanger
- Thermal Mass to Air
- Multistage Moisture Separation

High Strength Aluminium Design
Large Surface Area for Heat Transfer
Robust Cylindrical Casing

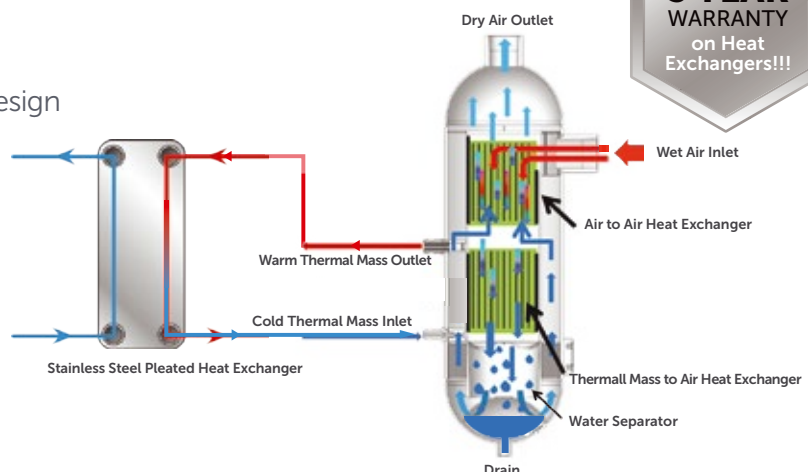

Scroll Refrigerant Compressors:

- Have fewer moving parts
- Offer smoother and quieter operation
- And are more reliable and more efficient than reciprocating types.

MCY Cycling Series-Working Principle

Moisture saturated Compressed Air from the Air Compressor enters a Particulate Pre-Filter then into the Thermal Mass Dryer-Compressed Air Travels through a Coalescing Pre Filter and then 3 in 1 Heat Exchanger.

As the compressed air passes through, it is then cooled by the cold Thermal Mass System and water vapor then condenses into liquid and is removed with the drain system.

Cold compressed air then passes by the incoming hot air to re-heat in order to prevent plant air pipes from sweating – then the dried compressed air passes through a Coalescing Post Filter and out to the customers application.

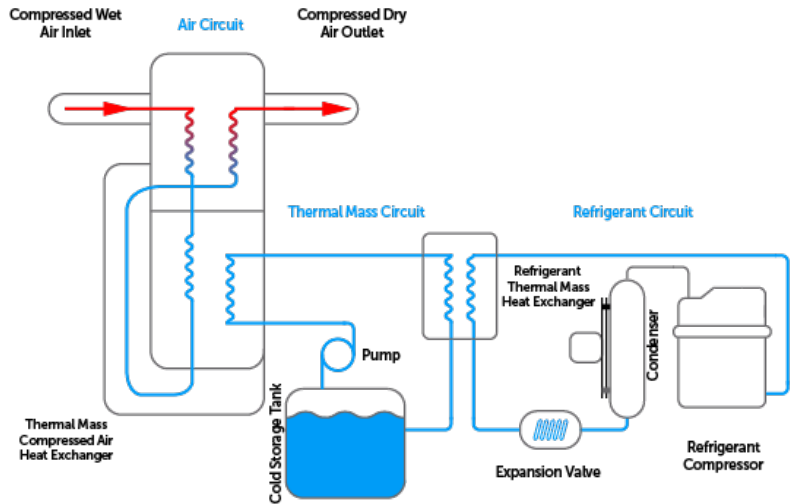

kW-CY Controllers (100 SCFM to 250 SCFM)

Mikropor MCY Series Air Dryers incorporate exclusive Digi-Pro series controller. The kW-CY digi-Pro controllers have outstanding technology for both functionality and durability in addition to visual appeal. The new controller design offers ease of adjustment with one finger, with accurate digital dew point display. In addition to coded alarm monitoring of the dryer.

Digital controller with embedded features

- Digital dew point monitoring
- Periodic maintenance interval display
- Status report
- Hours run meter
- Fahrenheit and Centigrade selection



Easy Service

Easy access into the cooling components in seconds by the help of "easy lift" panels with integrated finger slots. Simplifies service access with quick access by technicians (no screws / fasteners to remove).



kW-CY ESD Controller (1200 Nm³/h to 12500 Nm³/h units)

Mikropor MCY Series Air Dryers of larger capacity have ESD Digital Controller. With the help of the highly engineered kW-CY ESD Controller on the MCY Series Cycling Air dryers reduce energy consumption. The ESD interface assists the users to monitor many useful parameters on the dryer and guides them to troubleshoot any problem very easily. During the nights, weekends and holidays many companies do not stop their dryers although the compressors may be stopped. kW-CY ESD Controller saves huge amounts of money by simply shutting the dryer down automatically when it is not in use.



Grooved Couplings and Fittings

- The compressed air circuit utilizes grooved couplings and fittings to ensure a positive connection without leaks.
- These couplings assist the service technician to dismantle and assemble pipes easily and quickly.



Service Safety

- The GO Series Filter integration features.
- Zero Loss Drain system integration features.
- Manual valves allow the system to be depressurized safely when service is needed.



- Integral zero air loss drain
- No compressed air Loss
- Low maintenance design
- Reliable
- Robust low operating cost
- Simple installation

Zero Clearance Compressed Air Filters with High Performance Elements

Mikropor GKON Series compressed air filters are a MCY Series dryer standard. The X Pre-Filter (coalescing filter for water removal) is used for up to 1-micron particles and the Y Post Filter (coalescing filter for oil removal) is used to remove oil down to 0.01 ppm. Listening to customer needs our engineers created a service friendly design. The Zero clearance design helps service technicians to replace the element in just a few minutes.

The MCY Series dryer / filter combination has 2 elements and 2 Viton O-rings to ensure operation of the dryers at its best performance until the next planned maintenance.



Process Air Quality Protection

Pressure drop is a large concern in compressed air. In many applications high pressure drops will cause a decrease in the pressure at the point of use which results the machines or processes not operating correctly. Presence of dirt particles and oil in the compressed air system may result in filter blockage. It is important for the end users and service technicians to recognize if there is a problem in the system. The performance of the filters directly affects the pressure drops and system performance. Therefore, it is very important that the filter elements are changed at the filter service time. MCY Series Digital Controls feature an alarm/warning indicating the appropriate time to change the filter elements. When the indication should occur, the element change will assist to avoid loss of performance and pressure drop.

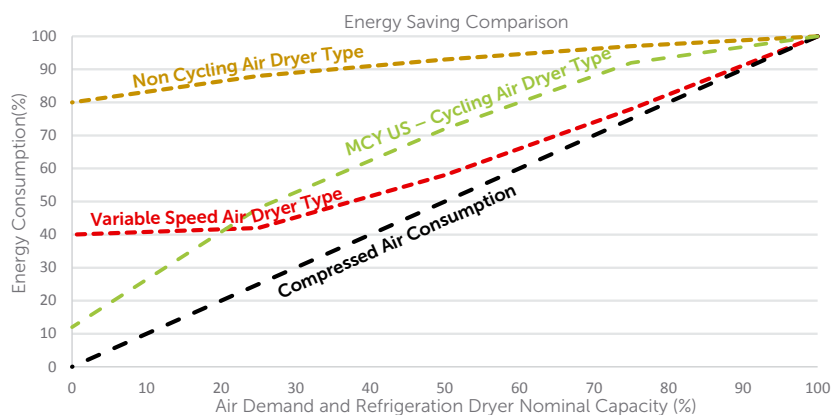
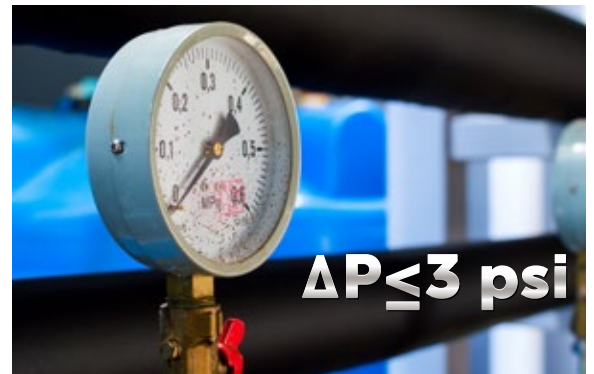

Correction Factor for MCY Air Dryers

Inlet Temperature (°C)	F1	Ambient Temperature (°C)	F2	Pressure (bar)	F3
30	1.29	20	1.05	4	0.80
35	1	25	1	6	0.94
40	0.92	30	0.98	7	1
45	0.78	35	0.93	8	1.04
50	0.65	40	0.84	10	1.11
60	0.45	50	0.7	12	1.16
65	0.38	-	-	14	1.22
-	-	-	-	16	1.25

Example for Choosing the Correct Dryer

If an air compressor delivers 500 m³/h at 6 bar, the dryer inlet temperature is 45°C and ambient temperature is 30°C

Please choose your dryer model as follows;
500 / 0.94 / 0.78 / 0.98 = 695 m³/h

The correct dryer model for this application is MCY930

MCY Series - Technical Specifications

Model	Capacity (m ³ /h)	Voltage	Connection Size	Filter Quantity and Type	Replacement Filter Element Kit	Dimensions (mm)		
						Length	Width	Height
MCY-495	495	230V / 1 Ph / 50 Hz	2"	1*GKON805X + 1*GKON805Y	MKON805 KIT	857	727	1505
MCY-623	623	230V / 1 Ph / 50 Hz	2"	1*GKON805X + 1*GKON805Y	MKON805 KIT	828	728	1763
MCY-930	930	230V / 1 Ph / 50 Hz	2"	1*GKON1205X + 1*GKON1205Y	MKON1205 KIT	828	728	1763
MCY-1200	1200	230V / 1 Ph / 50 Hz	2"	1*GKON1205X + 1*GKON1205Y	MKON1205 KIT	828	728	1763
MCY-1388	1388	400V / 3 Ph / 50 Hz	3"	1*GKON-HC-1805X + 1*GKON-HC-1805Y	MKON-HC-1805 KIT	1148	798	1739
MCY-1800	1800	400V / 3 Ph / 50 Hz	3"	1*GKON-HC-1805X + 1*GKON-HC-1805Y	MKON-HC-1805 KIT	1148	798	1739
MCY-2500	2500	400V / 3 Ph / 50 Hz	3"	1*GKON-HC-2775X + 1*GKON-HC-2775Y	MKON-HC-2775 KIT	1313	878	1788
MCY-2775	2775	400V / 3 Ph / 50 Hz	3"	1*GKON-HC-2775X + 1*GKON-HC-2775Y	MKON-HC-2775 KIT	1313	878	1788
MCY-3330	3330	400V / 3 Ph / 50 Hz	DN100 Flange	1*GKO5850X + 1*GKO5850Y	GKO5850 KIT	1577	993	1976
MCY-3915	3915	400V / 3 Ph / 50 Hz	DN100 Flange	1*GKO5850X + 1*GKO5850Y	GKO5850 KIT	1577	993	1976
MCY-5085	5085	400V / 3 Ph / 50 Hz	DN100 Flange	1*GKO5850X + 1*GKO5850Y	GKO5850 KIT	1797	1077	2075
MCY-5850	5850	400V / 3 Ph / 50 Hz	DN100 Flange	1*GKO5850X + 1*GKO5850Y	GKO5850 KIT	1797	1077	2075
MCY-6875	6875	400V / 3 Ph / 50 Hz	DN150 Flange	** Externally Connected - F6500 X / Y	6*M1200 KIT	2188	1062	2024
MCY-7875	7875	400V / 3 Ph / 50 Hz	DN150 Flange	** Externally Connected - F8500 X / Y	8*M1200 KIT	2188	1062	2024
MCY-9000	9000	400V / 3 Ph / 50 Hz	DN150 Flange	** Externally Connected - F11000 X / Y	10*M1200 KIT	2247	1551	2114
MCY-10500	10500	400V / 3 Ph / 50 Hz	DN200 Flange	** Externally Connected - F11000 X / Y	10*M1200 KIT	2247	1551	2114
MCY-12500	12500	400V / 3 Ph / 50 Hz	DN200 Flange	** Externally Connected - F14000 X / Y	14*M1200 KIT	2547	1547	2172

** Not integrated and not included in standard package

Nominal Working Pressure	7 barg
Maximum Working Pressure	16 barg
Minimum Working Pressure	4 barg
Nominal Inlet Temperature	35°C
Maximum Inlet Temperature	50°C

Minimum Inlet Temperature	5°C
Nominal Ambient Temperature	25°C
Maximum Ambient Temperature	45°C
Minimum Ambient Temperature	5°C
Refrigerant	R134a

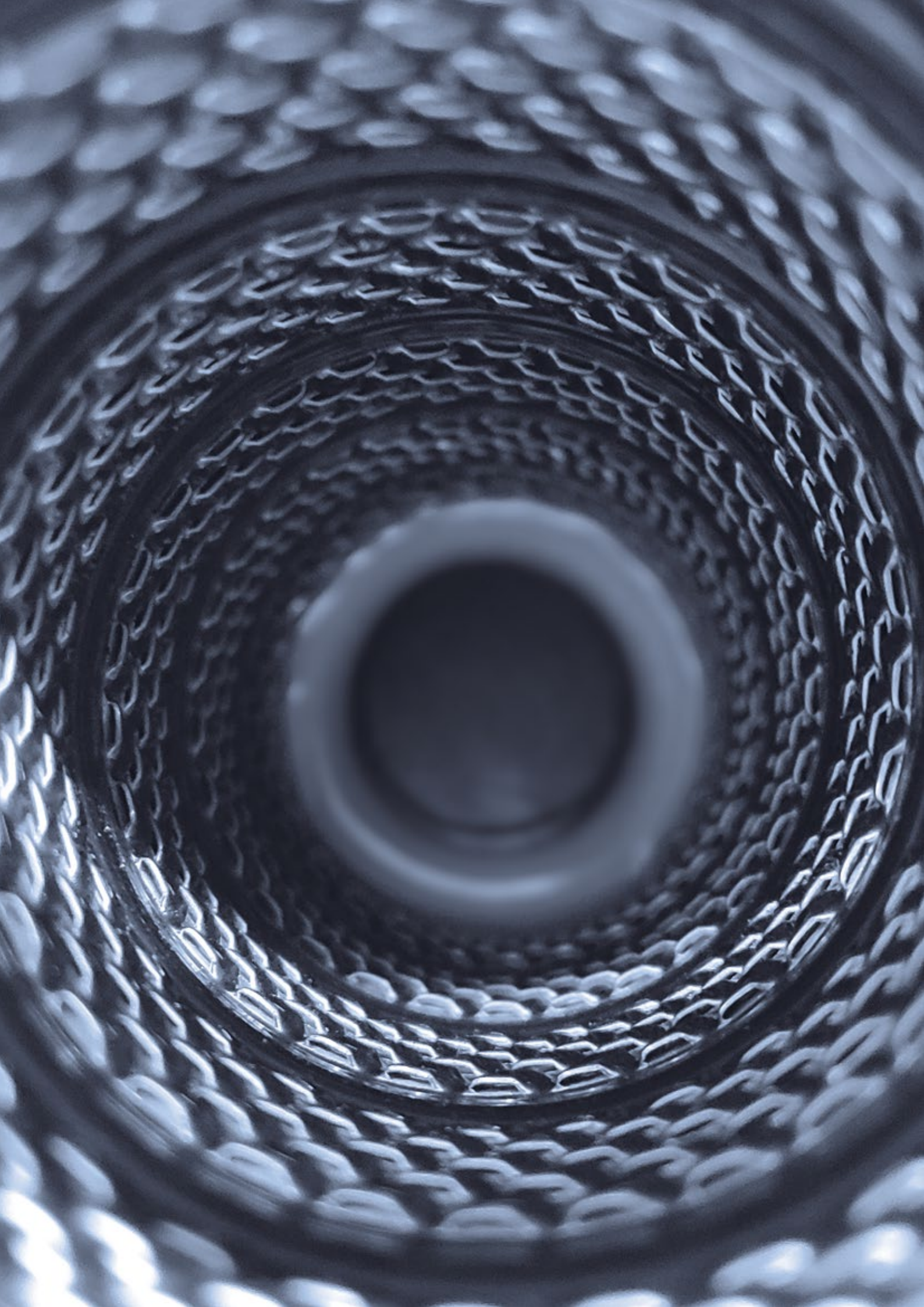

▶ MK-DS SERIES DIGITAL SCROLL INTEGRATED FILTRATION



COMPRESSED AIR DRYERS ◀

Each and every compressed air user around the world has been looking for a complete solution to associate the best practices of energy management with their refrigerated air dryers, not just to protect the environment, but also to save money on operating costs.

Mikropor is proud to announce that the new MK-DS series explicitly prevails over any other type of refrigerated air dryer by achieving everyone's goal to lower energy costs.

The MK-DS Series, with a specially designed heat exchanger and digital scroll compressor, provides unrivalled energy efficiency in a refrigerated air dryer.

The challenge of maintaining a stable dewpoint and saving energy can be overcome with this latest technological development.

Combining Mikropor's expertly designed heat exchanger, leading filtration technology and digital scroll compression in Mikropor's MK-DS dryers provides the ultimate energy efficiency solution for compressed air systems with varying levels of air demand.



Energy Comparison

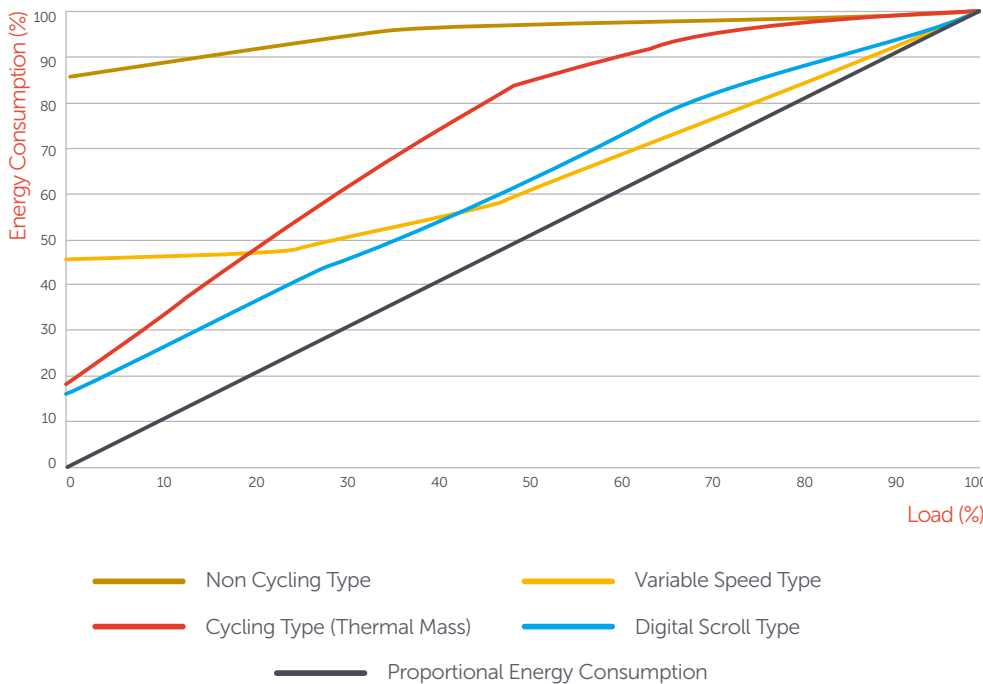

▶ MK-DS SERIES DIGITAL SCROLL INTEGRATED FILTRATION

COMPRESSED AIR DRYERS ◀

- **Best in Class** energy saving
- Refrigeration systems are designed with digital scroll compressors and have an automatic switch to control loaded and unloaded states according to real-time air load demand during system operation in order to maximize energy savings.
- Advanced and user friendly electronic control system
- Electronic expansion valve
- Fan speed control
- Integrated filters
- Low pressure drop
- Energy efficiency is maximized through the design of the exclusive aluminium plate type heat exchangers.
- The advanced digital scroll compression technology not only improves efficiency, durability and reliability but also lowers the decibel sound levels compared to a standard refrigerated air dryer.
- Environmentally friendly low-pressure R-134a refrigerant gas is used in digital scroll compressor to pressurize the system.
- The smart control unit named kW-DS Controller provides high energy efficiency with electricity consumption optimized for variable capacities.

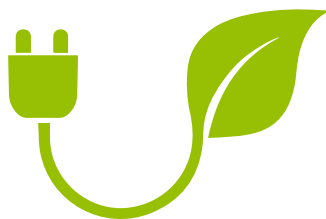

kW Saver



STABILITY

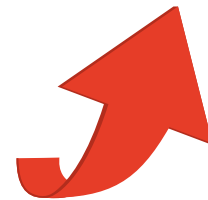

PERFORMANCE

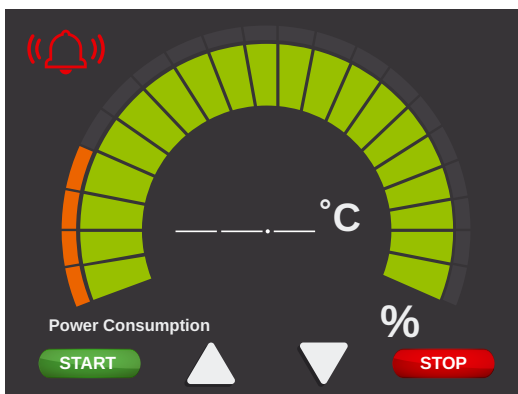

The advanced digital scroll technology utilized in Mikropor's MK-DS Series dryers maintains a stable pressure dew point while performing **up to 91% energy savings** during operation.

How It Works?

Unlike most refrigerated dryers in the industry, Mikopor's MK-DS series utilize a proprietary digital evaporator technology to deliver significant energy savings over traditional cycling and variable speed designs.

This brand new technological breakthrough offers a vital opportunity to save the highest amount of energy possible in a refrigerated air dryer. The digital compressor operates with various different ranges of inlet flow conditions which also makes it by far the most energy efficient compressor to be utilized in a refrigerated air dryer.

MK-DS Dryers are equipped with a true no-loss condensate drain which provides effective condensate removal without any loss of (valuable) compressed air.

Maximum energy savings are achieved by establishing continuous communication with the temperature probe in the evaporator which adjusts the refrigeration pressure to the temperature of the air exiting the evaporator.

Fundamental Components of the MK-DS Series

- Digital Scroll Compressor
- Electronic Expansion Valve
- Variable Speed Fan Motor
- Highly Engineered Control Algorithm
- Cutting-Edge Technology Electronic Controller

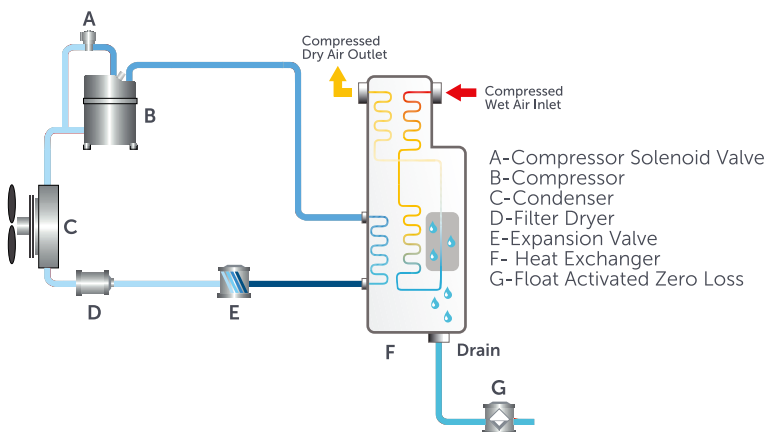

Mikopor's latest MK-DS series refrigerated dryer technology saves the highest amount of energy possible on the market.

Why is MK-DS so energy efficient and cost effective ?

Non-cycling refrigerated dryers are designed to run continuously and consume almost 100% of the nominal power at all loads. Hence, it makes no difference if a facility is operational or not - A non-cycling dryer will just keep running, regardless of the air demand at any given time. As mentioned above, digital scroll technology equipped dryers can be loaded or unloaded automatically depending upon the real-time air load demand and this feature simply makes the MK-DS range much more energy efficient than any other type of refrigerated air dryer.

With the energy savings calculation tool, the users can compare how much energy can be saved for different dryer selections.

ENERGY SAVING CALCULATION			
Energy Unit Price	0,06	€/kWh	
Daily Working Hours	24	hour	
Monthly Working Days	30	day	
SELECTED AIR DRYER MODELS			
	DIGITAL SCROLL AIR DRYER MK-DS 260	VS	STANDARD AIR DRYER MKE 12500
Monthly Ener. Consumption	6882 kWh		13417 kWh
Total Power Savings	Total Power Savings Annual	Total Cost Saved Annual	
49%	78415 kWh	€ 4.705	

Energy Saving Example

Consider a 12500 Nm³/h non-cycling refrigerated air dryer running continuously for 720 hours monthly at an average energy cost of €0.06 per kWh.

In this scenario the non-cycling air dryer will consume 13417 kWh of electricity.

An equivalent MK-DS air dryer, rated at 12500 Nm³/h operating at the same conditions over the same period, would consume 6882 kWh.

Consequently the MK-DS air dryer will achieve energy savings of € 4.705 compared to a non-cycling air dryer per annum.

MK-DS Series - Technical Specifications

Model	Capacity (m ³ /h)	Voltage	Connection Size	Filter Quantity and Type	Replacement Filter Element Kit	Control Type
MK-DS-120	930	400V / 3 Ph / 50 Hz	2"	1*GKON1205X + 1*GKON1205Y	MKON1205 KIT	µPc
MK-DS-130	1200	400V / 3 Ph / 50 Hz	2"	1*GKON1205X + 1*GKON1205Y	MKON1205 KIT	µPc
MK-DS-140	1388	400V / 3 Ph / 50 Hz	3"	1*GKON-HC-1805X + 1*GKON-HC-1805Y	MKON-HC-1805 KIT	µPc
MK-DS-150	1800	400V / 3 Ph / 50 Hz	3"	1*GKON-HC-1805X + 1*GKON-HC-1805Y	MKON-HC-1805 KIT	µPc
MK-DS-170	2775	400V / 3 Ph / 50 Hz	3"	1*GKON-HC-2775X + 1*GKON-HC-2775Y	MKON-HC-2775 KIT	µPc
MK-DS-180	3330	400V / 3 Ph / 50 Hz	DN100 Flange	1*GKO5850X + 1*GKO5850Y	GKO5850 KIT	µPc
MK-DS-190	3915	400V / 3 Ph / 50 Hz	DN100 Flange	1*GKO5850X + 1*GKO5850Y	GKO5850 KIT	µPc
MK-DS-200	5085	400V / 3 Ph / 50 Hz	DN100 Flange	1*GKO5850X + 1*GKO5850Y	GKO5850 KIT	µPc
MK-DS-210	5850	400V / 3 Ph / 50 Hz	DN100 Flange	1*GKO5850X + 1*GKO5850Y	GKO5850 KIT	µPc
MK-DS-220	6975	400V / 3 Ph / 50 Hz	DN150 Flange	** Externally Connected - F6500 X / Y	6*M1200 KIT	µPc
MK-DS-230	7875	400V / 3 Ph / 50 Hz	DN150 Flange	** Externally Connected - F8500 X / Y	8*M1200 KIT	µPc
MK-DS-240	9000	400V / 3 Ph / 50 Hz	DN150 Flange	** Externally Connected - F11000 X / Y	10*M1200 KIT	µPc
MK-DS-250	10500	400V / 3 Ph / 50 Hz	DN200 Flange	** Externally Connected - F11000 X / Y	10*M1200 KIT	µPc
MK-DS-260	12500	400V / 3 Ph / 50 Hz	DN200 Flange	** Externally Connected - F14000 X / Y	14*M1200 KIT	µPc

Nominal Working Pressure	7 barg
Maximum Working Pressure	16 barg
Minimum Working Pressure	4 barg
Nominal Inlet Temperature	35°C
Maximum Inlet Temperature	50°C

Minimum Inlet Temperature	5°C
Nominal Ambient Temperature	25°C
Maximum Ambient Temperature	45°C
Minimum Ambient Temperature	5°C
Refrigerant	R134a

▶ MK-HP SERIES HIGH PRESSURE

COMPRESSED AIR DRYERS ◀

This design achieves a hyper-efficient 100% contact between the air and refrigerant circuits, delivering state-of-the-art performance and great cooling efficiency.





The state-of-the-art 3-in-1 design features very low differential pressure delivering significant energy savings. The 3-in-1 Heat-Exchanger is compact and allows the dryer to be smaller and reduces the space required for the dryer. Mikropor offers a variety of 3-in-1 dryers equipped with the 3-in-1 Heat-Exchanger to meet a full range of capacity and power requirements.



40 bar



Mikropor High Pressure Dryers have stainless steel brazed plate heat exchangers.

-  Size Reduced by 50%
-  Dewpoint 3°C
-  Stainless Steel, Anti-corrosion
-  Working Pressure Up to 45 bar
-  Inlet/Outlet Temp. Difference <10°C

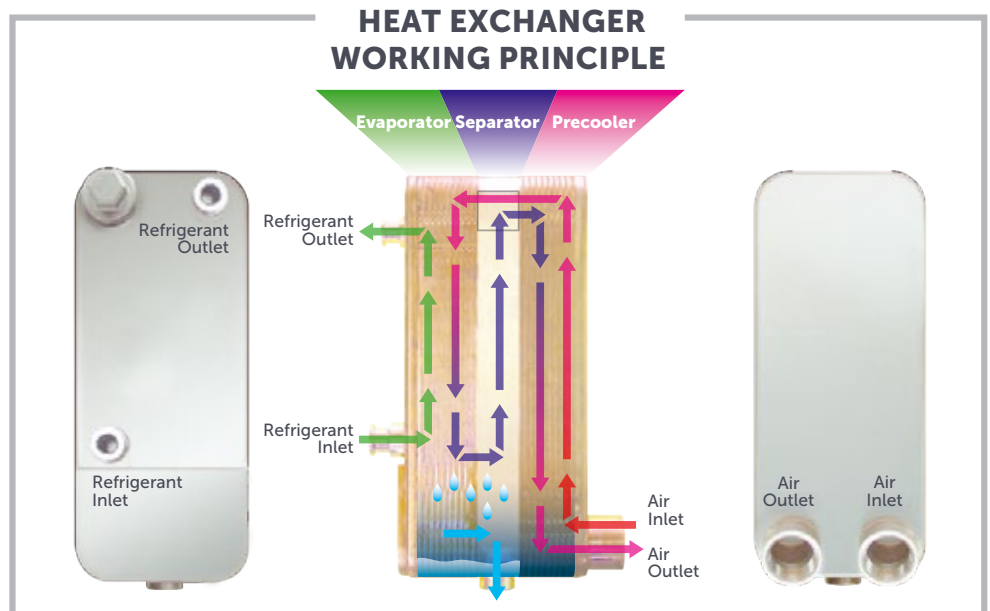

Mikropor MK-HP range High Pressure Air Dryer Series have state of the art stainless steel brazed plate heat exchanger. It is designed for high pressure air dryers. The heat exchanger has the following sections in one module;

- Air/Air heat exchanger (Economizer)
- Air/Refrigerant heat exchanger (Evaporator)
- Water separator

With reliable stainless steel and optimized efficiency design, Mikropor MK-HP heat exchangers supply size reduction, anti corrosion and great heat transfer.

The Separator Efficiency

- Double centrifugation due to the bottom fin
- Reserved direction for the compressed air
- Gravity effect to the condensed water
- Special anti-return system
- Separator integrated to the system

Frigorific Circuit

- Two valve regulation system (thermal and by-pass), allowing to fill properly the exchanger and giving a max. temperature to the exchanger
- High quality security test of potential leakage
- Use of hermetic compressor as standard
- High quality, long lasting components
- Quick start and reaction time

Scroll Compressor

- Better coefficient of power
- Less energy consumption
- Higher resistance to liquid shocks



Technical Specifications

Model	Capacity (m ³ /h)	Voltage	Connection Size	Dimensions (mm)		
				Width	Length	Height
MK-HP-50	50	230V / 1 Ph / 50 Hz	3/4"	454	361	553
MK-HP-90	90	230V / 1 Ph / 50 Hz	3/4"	454	361	553
MK-HP-150	150	230V / 1 Ph / 50 Hz	3/4"	453	401	623
MK-HP-220	220	230V / 1 Ph / 50 Hz	3/4"	453	401	623
MK-HP-300	300	230V / 1 Ph / 50 Hz	1 1/4"	505	451	762
MK-HP-400	400	230V / 1 Ph / 50 Hz	1 1/4"	505	451	762
MK-HP-500	500	230V / 1 Ph / 50 Hz	1 1/4"	505	451	812
MK-HP-575	575	230V / 1 Ph / 50 Hz	1 1/4"	505	451	812
MK-HP-775	775	230V / 1 Ph / 50 Hz	1 1/4"	675	501	984
MK-HP-910	910	230V / 1 Ph / 50 Hz	1 1/4"	675	501	984
MK-HP-1000	1000	230V / 1 Ph / 50 Hz	2"	947	727	1169
MK-HP-1160	1160	230V / 1 Ph / 50 Hz	2"	947	727	1169
MK-HP-1500	1500	230V / 1 Ph / 50 Hz	2"	947	727	1169
MK-HP-1600	1600	400V / 3 Ph / 50 Hz	2"	947	727	1459
MK-HP-1800	1800	400V / 3 Ph / 50 Hz	2"	947	727	1459
MK-HP-2200	2200	400V / 3 Ph / 50 Hz	2 1/2"	1162	797	1495
MK-HP-2500	2500	400V / 3 Ph / 50 Hz	2 1/2"	1162	797	1495
MK-HP-2700	2700	400V / 3 Ph / 50 Hz	2 1/2"	1162	797	1495
MK-HP-3000	3000	400V / 3 Ph / 50 Hz	2 1/2"	1162	797	1495
MK-HP-3300	3300	400V / 3 Ph / 50 Hz	2 1/2"	1162	797	1495
MK-HP-3600	3600	400V / 3 Ph / 50 Hz	2 1/2"	1162	797	1495

Correction Factor for MK-HP Series

Pressure (bar)	F1	Inlet Temp. (°C)	F2	Ambient Temp. (°C)	F3
-	-	-	-	7	0,20
-	-	-	-	10	0,28
-	-	-	-	13	0,34
-	-	-	-	15	0,40
-	-	-	-	20	0,50
-	-	-	-	25	0,60
-	-	-	-	30	0,75
-	-	-	-	35	0,85
35	1	25	1	40	1
40	0,85	30	0,93	45	1,10
45	0,72	35	0,87	-	-
50	0,63	40	0,82	-	-
-	-	45	0,79	-	-

Nominal Working Pressure	40 barg	Minimum Inlet Temperature	5°C
Maximum Working Pressure	45 barg	Nominal Ambient Temperature	25°C
Minimum Working Pressure	7 barg	Maximum Ambient Temperature	45°C
Nominal Inlet Temperature	35°C	Minimum Ambient Temperature	5°C
Maximum Inlet Temperature	50°C	Refrigerant	R134a

AIR LINE DESIGN	AIR LINE DESIGN 1	APPLICATION	ISO 8573.1: 2010 CLASS
	<p>COMPRESSED AIR FILTERS</p>	SIMPLE	2.-3
	<p>COMPRESSED AIR FILTERS</p> <p>REFRIGERANT AIR DRYER</p> <p>COMPRESSED AIR FILTERS</p>	GENERAL PURPOSE	1.4.1
	<p>COMPRESSED AIR FILTERS</p> <p>REFRIGERANT AIR DRYER</p> <p>COMPRESSED AIR FILTERS</p>	ODORLESS	1.4.1
	<p>COMPRESSED AIR FILTERS</p> <p>COMPRESSED AIR FILTERS</p> <p>DESICCANT DRYER</p> <p>COMPRESSED AIR FILTERS</p>	CRITICAL	1.2.1 (-40 °C / -40°F) 1.1.1 (-70 °C / -94 °F)

Purity Class	ISO 8573.1: 2010 Compressed Air Quality Standard							
	Solid Particulate					Water		Oil
	Max. number of Particles per m ³			Particle Size (micron)	Concentration (mg/m ³)	Vapor Pressure Dew Point	Liquid (g/m ³)	Total Oil (Aerosol, Liquid and Vapor) (mg/m ³)
	0.1-0.5 micron	0.5-1 micron	1-5 micron					
0	As specified and determined by equipment user and supplier							
1	≤20000	≤400	≤10	-	-	≤-70°C	-	≤0.01
2	≤400000	≤6000	≤100	-	-	≤-40°C	-	≤0.1
3	-	≤900000	≤1000	-	-	≤-20°C	-	≤1
4	-	-	≤10000	-	-	≤+3°C	-	≤5
5	-	-	≤100000	-	-	≤+7°C	-	-
6	-	-	-	5	5	≤+10°C	-	-
7	-	-	-	40	10	-	0.5	-
8	-	-	-	-	-	-	5	-
9	-	-	-	-	-	-	10	-

for Solid Particles	for Water	for Oil
Element Type P - Class 3	Mikropor Refrigerated Air Dryers are Class 3	Element Type P - Class 3
Element Type X - Class 2		Element Type X - Class 2
Element Type Y - Class 1		Element Type Y - Class 1
Element Type A - N/A	Mikropor Desiccant Air Dryers are Class 1 and 2	Element Type A - Class 1 (when used with Y)

The light weight modular design desiccant dryer series brings a new concept in compressed air technology, offering total installation flexibility to meet specific needs.

Mikropor's Modular Desiccant Dryers are less than half the weight and size of a traditional twin tower design, allowing even the largest models to be easily moved through a standard doorway. Mikropor's innovative Modular Air Dryers make it easier and more affordable than ever to deliver high-quality compressed air for virtually wherever it's needed.

Mikropor Modular Desiccant Dryers have cosmetic beauty and can be located in clean, pleasant environments eyesore. Offered in sizes from 5 m³/h to 400 m³/h with dew point of -40°C to -70°C (optional) these dryers are equipped with everything you need, requiring only air inlet/outlet connections.

Using a highly engineered inlet and purge manifold design, Mikropor proudly offers one of the lowest pressure drop desiccant dryer in the industry.

- Small footprint, lightweight, advanced compact design
- Corrosion protected Aluminium construction
- Hassle-free, reliable electronic controls
- Can be floor, bench or wall mounted
- Quiet enough to be placed in any work environment
- Easy installation, easy maintenance

The new Modular Desiccant Dryers combine proven traditional dryer principles with the latest technology to provide unsurpassed efficiency, flexibility and world-renowned Mikropor reliability for your critical dry air applications.

Various Application Options

Modular Desiccant Air Dryers can be mounted to the wall with easy-to-use mounting brackets to free up additional space and can also be secured to the ground very easily.



Technical Specifications

Model	Capacity		Voltage	Connection Size	Max. Working Pressure (bar)	Dimensions			
	(m ³ /h)	(cfm)				Width (mm)	Length (mm)	Height (mm)	Weight (kg)
MMD3	5	3	115-240V/50-60 Hz.	1/2"	16	320	336	558	17
MMD5	10	5	115-240V/50-60 Hz.	1/2"	16	320	320	633	19
MMD10	20	10	115-240V/50-60 Hz.	1/2"	16	320	320	908	27
MMD15	25	15	115-240V/50-60 Hz.	1/2"	16	370	350	808	31
MMD20	35	20	115-240V/50-60 Hz.	1/2"	16	370	350	1108	42
MMD25	45	25	115-240V/50-60 Hz.	1/2"	16	370	350	1258	48
MMD30	50	30	115-240V/50-60 Hz.	1/2"	16	370	350	1508	54
MMD40	70	40	115-240V/50-60 Hz.	1 1/2"	16	410	495	1250	71
MMD50	85	50	115-240V/50-60 Hz.	1 1/2"	16	410	495	1400	78
MMD60	100	60	115-240V/50-60 Hz.	1 1/2"	16	410	495	1750	92
MMD75	130	75	115-240V/50-60 Hz.	1 1/2"	16	430	622	1300	120
MMD100	170	100	115-240V/50-60 Hz.	1 1/2"	16	430	622	1450	133
MMD120	200	120	115-240V/50-60 Hz.	1 1/2"	16	430	622	1750	152
MMD180	300	180	115-240V/50-60 Hz.	1 1/2"	16	410	734	1499	186
MMD240	400	240	115-240V/50-60 Hz.	1 1/2"	16	410	889	1497	235

Pressure Dew Point	Nominal Inlet Temperature	Nominal Working Pressure	Maximum Inlet Temperature	Maximum Working Pressure	Maximum Ambient Temperature
-40°C / -70°C (opt)	35°C	7 bar	50°C	16 bar	50°C

Given flows are at 7 barg pressure with reference to 20°C and 1 bar atmospheric air suction as per ISO7183.

Correction Factor for MMD Series

Pressure (bar)	F1	Inlet Temp. (°C)	F2
4.5	0.69	20	1
5	0.75	25	1
6	0.88	30	1
7	1	35	1
8	1.12	40	0.80
9	1.25	45	0.73
10	1.25	50	0.59
11	1.50	-	-
12	1.62	-	-
13	1.74	-	-
14	1.87	-	-
15	1.99	-	-
16	2.11	-	-

PLC Monitor

The mini PLC is user friendly and shows the working action simultaneously. It is possible to get an alarm signal or remote control thanks to an easy access plug below the dryer. Dew point control and monitoring is possible with a dew point sensor.

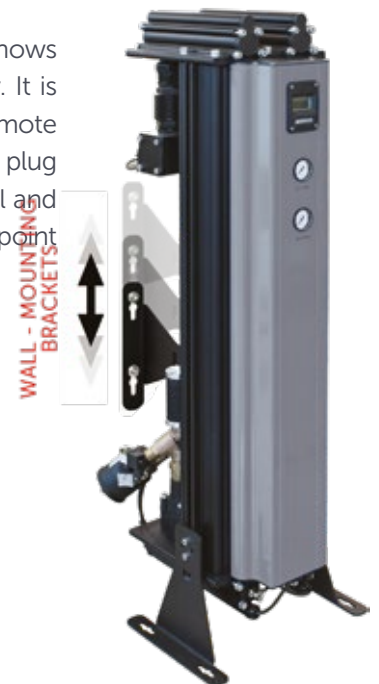



yeni görsel gelecek

PLC

MDA Desiccant Dryers have an extremely reliable electronic controller for optimal performance over the lifetime of the dryers. The touch screen PLC is capable of showing the cycles as well as the valves as they operate in real time. This is also capable of showing dew points. User friendly multi-lingual PLC helps the end users understand the operation of the system and identify any issues easily.

Correction Factor for MDA Series

Pressure (bar)	F1	Inlet Temp. (°C)	F2
4.5	0.69	20	1
5	0.75	25	1
6	0.88	30	1
7	1	35	1
8	1.12	40	0.80
9	1.25	45	0.73
10	1.37	50	0.59

All desiccant dryers are designed according to Pneurop conditions as per ISO 7183.

Ordering

If a compressor delivers 850 m³/h at 9 bar pressure and 45°C inlet temperatures please choose your dryer as follows; $850/1.25/0.73 = 931 \text{ m}^3/\text{h}$ the correct dryer for this is MDA1000



Activated Alumina

In order to achieve consistent dew point, Mikropor uses a mixture of adsorption media in its heatless range of desiccant dryers. Activated Alumina, Molecular Sieve and Silica Gel are used in varying ratios depending on the application.

Technical Specifications

Model	Connection Size	Inlet Flow Rate		Voltage	Max. Working Pressure (bar)	Pressure Drop (mbar)	Total Weight (Packed) (kg)	Activated Alumina (kg)	Dimensions (mm)		
		(m ³ /h)	(cfm)						Width	Length	Height
MDA 130	1"	130	80	230/1/50-60	10	≤130	160	40	600	814	1312
MDA 185	1"	185	100	230/1/50-60	10	≤130	180	54	600	808	1566
MDA 250	1"	250	150	230/1/50-60	10	≤130	200	75	760	772	1580
MDA 300	1 1/2"	300	200	230/1/50-60	10	≤130	250	100	690	900	1558
MDA 360	1 1/2"	360	215	230/1/50-60	10	≤130	250	100	690	900	1558
MDA 440	1 1/2"	440	250	230/1/50-60	10	≤130	340	1250	698	900	1759
MDA 575	1 1/2"	575	300	230/1/50-60	10	≤130	500	151	680	900	1991
MDA 680	2"	680	400	230/1/50-60	10	≤130	535	202	680	960	2216
MDA 850	2"	850	500	230/1/50-60	10	≤130	750	264	857	1016	2277
MDA 1000	2"	1000	600	230/1/50-60	10	≤130	755	357	1010	1075	2386
MDA 1250	DN80/PN16	1250	700	230/1/50-60	10	≤130	1000	404	1100	1294	2413
MDA 1500	DN80/PN16	1500	800	230/1/50-60	10	≤130	1050	454	1010	1300	2547
MDA 1800	DN80/PN16	1800	1000	230/1/50-60	10	≤130	1215	566	1110	1513	2479
MDA 2200	DN80/PN16	2200	1250	230/1/50-60	10	≤130	1550	708	1110	1460	2793
MDA 2700	DN80/PN16	2700	1500	230/1/50-60	10	≤130	1890	852	1252	1533	2831
MDA 3200	DN100/PN16	3200	1750	230/1/50-60	10	≤130	2240	954	1212	1653	3054
MDA 3600	DN100/PN16	3600	2000	230/1/50-60	10	≤130	2330	1070	1210	1653	3268
MDA 4400	DN100/PN16	4400	2500	230/1/50-60	10	≤130	3000	1436	1535	1905	2910
MDA 5000	DN150/PN16	5000	3000	230/1/50-60	10	≤130	3180	1670	1714	1843	3382
MDA 6300	DN150/PN16	6300	4000	230/1/50-60	10	≤130	3450	2016	1693	2114	3328
MDA 7200	DN150/PN16	7200	4500	230/1/50-60	10	≤130	3600	2446	1795	2518	3047
MDA 8800	DN150/PN16	8800	5000	230/1/50-60	10	≤130	3850	2906	1795	2518	3341
MDA 10800	DN200/PN16	10800	6000	230/1/50-60	10	≤130	4200	3354	1875	2583	3747
MDA 12500	DN200/PN16	12500	7360	230/1/50-60	10	≤130	6470	3894	1935	2545	4175

Given flows are at 7 barg pressure with reference to 20°C and 1 bar atmospheric air suction as per ISO7183.

Efficiency Rating	X Pre Filter	Y Pre Filter	P After Filter
		1 micron particle removal and 0.5 mg/m ³ oil removal	0.01 micron particle removal and 0.1 mg/m ³ oil removal

*For special requirements please contact our Technical Department.

Pressure Dew Point	Nominal Inlet Temperature	Nominal Working Pressure	Maximum Inlet Temperature	Maximum Working Pressure	Maximum Ambient Temperature
-40°C / -70°C (opt)	35°C	7 bar	50°C	10 bar	50°C

Mikropor MDA Heatless Desiccant Air Dryers provide constant -40°C (-70°C Optional) pressure dew point. These dryers are designed to supply clean and very dry compressed air for critical applications. Pre-filters and after-filters are standard on all Mikropor Heatless Air Dryers to keep the air stream clean and maintain the integrity of the desiccant medium. A very reliable electronic controller is utilised so the dryer operates perfectly through its service life. MDA Heatless Desiccant Dryers are equipped with special valves and high quality desiccants in order to assure performance and provide the lowest pressure drops available in the market.

Principle of Operation

The twin tower design allows for continuous adsorption of water vapor from compressed air by using the hygroscopic desiccant with high crush strength and a high surface/volume ratio. Drying is accomplished by passing compressed air through one desiccant bed adsorbing moisture while the other is being simultaneously regenerated with the expanded purge air.

Regeneration of desiccant is accomplished without the use of heat. The wet bed is dried by diverting a small portion of the super-dry air from the outlet at near atmospheric pressure. The purge flow rate is adjustable to suit the specific outlet conditions (desired dew point). The super dry air flows in a counter direction through the wet bed, sweeping all the water vapor previously absorbed by the desiccant. MDA ensures pressure equalization in the twin towers prior to switching.

This prevents line surge and minimizes desiccant attrition. The tower being reactivated will be gradually re-pressurized at the end of its reactivation cycle before switch over takes place. Purge flow and de-pressurization are in downward direction, counter to the drying air flow.

This saves ENERGY and helps the world become more "GREEN"



A centrifugal blower and high efficiency heater eliminate the use of valuable compressed air for desiccant regeneration. The completely automatic drying system uses blower to pull ambient air and pass it through the heater. This hot air stream flows opposite to drying flow direction. Hot air above 200°C regenerates the moisture inside desiccant bed and strips it completely of all moisture. The advanced control system monitors the dew point and adjusts the heating/regeneration accordingly thereby providing valuable energy savings.

- Dew point monitoring and control
- Computer Control-Display Status
- Display Alarms-Display Pressure
- Remote Start/Stop-Low Pressure Alarm
- Minimum pressure monitoring valve
- High pressure switches and alarms
- Externally heated or heatless dryer functions integrated to the MBP



Correction Factor for MBP Series

Pressure (bar)	F1	Inlet Temp. (°C)	F2
4.5	0.69	20	1
5	0.75	25	1
6	0.88	30	1
7	1	35	1
8	1.12	40	0.80
9	1.25	45	0.73
10	1.37	-	-

Technical Specifications

Model	Capacity (m ³ /h)	Connection Size	Max. Working Pressure (bar)	Pressure Drop (mbar)	Voltage	Average Power (kw)	Fuse Amp.	Activated Alumina (kg)	Dimensions (mm)		
									Width	Length	Height
MBP 850	850	2"	10	≤130	400/3/50	9,4	36	264	1290	1180	2299
MBP 1000	1000	2"	10	≤130	400/3/50	9,4	36	357	1200	1310	2415
MBP 1250	1250	DN80	10	≤130	400/3/50	12	50	404	1610	1270	2468
MBP 1500	1500	DN80	10	≤130	400/3/50	12	50	454	1610	1270	2563
MBP 1800	1800	DN80	10	≤130	400/3/50	14,5	65	566	1563	1515	2479
MBP 2200	2200	DN80	10	≤130	400/3/50	17,5	70	708	1563	1455	2789
MBP 2700	2700	DN80	10	≤130	400/3/50	21,4	87	852	1615	1514	2836
MBP 3200	3200	DN100	10	≤130	400/3/50	21,4	87	954	1710	1660	3054
MBP 3600	3600	DN100	10	≤130	400/3/50	31,1	121	1070	1710	1660	3268
MBP 4400	4400	DN100	10	≤130	400/3/50	36,1	121	1436	1975	2492	2910
MBP 5000	5000	DN125	10	≤130	400/3/50	39,4	136	1670	2045	2560	3382
MBP 6300	6300	DN150	10	≤130	400/3/50	49,4	170	2016	2090	2963	3328
MBP 7200	7200	DN150	10	≤130	400/3/50	49,4	170	2446	2020	3363	3047
MBP 8800	8800	DN150	10	≤130	400/3/50	72,3	250	2906	2020	3363	3341
MBP 10800	10800	DN200	10	≤130	400/3/50	78,7	280	3354	2492	3481	3765

Given flows are at 7 barg pressure with reference to 20°C and 1 bar atmospheric air suction as per ISO7183.

Pressure Dew Point	Nominal Inlet Temperature	Nominal Working Pressure	Maximum Inlet Temperature	Maximum Working Pressure	Maximum Ambient Temperature
-40°C	35°C	7 bar	45°C	10 bar	40°C

-70°C (optional)



04

GAS PRODUCTION AND TREATMENT SYSTEMS

MNG SERIES	PSA NITROGEN GENERATOR	68
MDX SERIES	NITROGEN PURIFIER SYSTEM	74
MCT SERIES	ACTIVATED CARBON TOWER	78
MBS SERIES	BREATHING AIR SYSTEM	80



GAS PRODUCTION AND
TREATMENT SYSTEMS

▶ MNG SERIES PSA NITROGEN GENERATOR

Pressure Swing Adsorption (PSA) type Nitrogen Generation system that is used to separate and enrich Nitrogen from Oxygen employs CMS (Carbon Molecular Sieve) for adsorbent. Carbon Molecular Sieve (CMS) adsorbs Oxygen and Water Vapor molecules under certain pressure while allowing Nitrogen to pass through.

The Nitrogen Generator is a Two-Bed Adsorber System

The Nitrogen Generator consists of two adsorber vessels filled with CMS, a valve assembly, air filters, main pressure regulator, and a product receiver tank. Clean and dry air is directed to one of the adsorber beds where oxygen and water vapor is adsorbed faster than nitrogen in the pore structure of the CMS, thus increasing the nitrogen purity of the product gas stream to the desired level (95-99.999% as required by customer). This product flows out from the top of the adsorber bed, through the valve and into the product receiver at a pressure slightly below the feed air pressure.

Applications

- Metal industry
- Chemical industry
- Purge
- Plastic industry
- Charge nitrogen gas in tires
- Production process and storage of food

Standard

- Oxygen Analyzer / Nitrogen Purity Sensor
- Flow Meter
- Carbolescer with oil indicator
- Nitrogen Generator / Silencer
- Basic Logo or Crouzet mini plc for modular type
- Siemens HMI color touch screen PLC for twin towers
- Buffer Tank (Standard for MNG 10 to MNG 2050)
- T Filters are standard in all models

Optional

- Dew Point Sensor

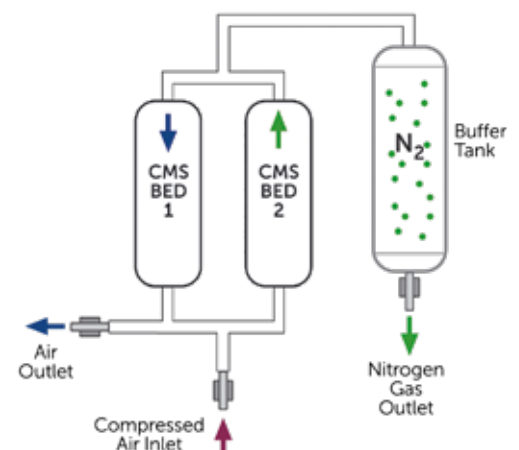

Features

- Simple structure, compact design, full automated operation
- Replaces manifold usage (see pic .1)
- Touch Screen PLC for controlling the complete system (see pic. 2)
- PLC Screen for monitoring and visualizing the progress
- Rapid start-up and safety system
- Superior silencer design gives low noise levels during depressurization and purge
- Durable piston valves for long-life operation (see pic. 5)
- On demand production, low cost
- High performance
 - *The purity and capacity of nitrogen gas is designed to meet customer requirements (Nitrogen Purity 95%~99.999% is available)
- Minimum maintenance cost.
 - *Replace filter element periodically only and service your compressor as normal



Replaces Manifold Usage - Pic. 1



Touch Screen PLC - Pic. 2



Dew Point Sensor - Pic. 3



Long Life Piston Valve - Pic. 5



Air Filter

Technical Specifications

Model	Air Demand @ Following Purity Level (m ³ /h)									
	95%	97%	98%	99%	99.50%	99.90%	99.95%	99.99%	99.999%	
MNG-10	5,6	5,0	4,5	4,0	3,6	3,1	2,8	2,5	2,0	Modular
MNG-20	9,0	8,0	7,3	6,4	6,2	5,0	4,5	4,0	3,3	
MNG-35	16,6	14,8	13,4	11,8	10,8	9,1	8,3	7,4	6,0	
MNG-60	27,6	24,6	22,4	19,6	17,9	15,2	13,8	12,3	10,0	
MNG-95	47,5	42,4	38,5	33,7	30,9	26,2	23,7	21,1	17,2	
MNG-120	63,4	56,6	51,4	45,1	41,3	35,0	31,7	28,2	23,0	
MNG-150	77,6	69,2	62,9	55,1	50,5	42,9	38,8	34,5	28,1	
MNG-250	123,5	110,2	100,1	87,7	80,4	68,3	61,7	55,0	44,8	
MNG-330	163,5	145,8	132,5	116,1	106,4	90,3	81,7	72,7	59,3	
MNG-450	220,9	197,0	179,1	156,9	143,8	122,1	110,4	98,3	80,1	
MNG-510	253,0	225,7	205,1	179,8	164,7	139,8	126,5	112,6	91,7	
MNG-570	281,0	250,6	227,8	199,6	182,9	155,3	140,5	125,1	101,9	
MNG-730	367,8	328,1	298,2	261,3	239,3	203,3	183,9	163,7	133,3	
MNG-910	450,0	401,3	364,8	319,6	292,8	248,7	224,9	200,2	163,1	
MNG-1110	547,0	487,9	443,5	388,6	355,9	302,3	273,4	243,4	198,3	
MNG-1230	603,4	538,2	489,2	428,7	392,7	333,5	301,6	268,5	218,8	
MNG-1370	668,6	596,4	542,1	475,0	435,1	369,5	334,2	297,6	242,4	
MNG-1820	904,1	806,3	732,9	642,2	588,3	499,6	451,9	402,3	327,7	
MNG-2050	1054,7	940,3	854,7	748,9	686,0	582,6	527,0	469,2	382,2	
MNG-2550	1263,9	1127,2	1024,6	897,8	822,4	698,4	631,8	562,5	458,2	
MNG-2950	1558,9	1390,4	1263,8	1107,4	1014,4	861,5	779,2	693,8	565,1	
MNG-3540	1827,0	1629,5	1481,1	1297,8	1188,8	1009,6	913,2	813,1	662,3	
MNG-4160	2106,8	1879,0	1708,0	1496,6	1370,9	1164,2	1053,1	937,6	763,7	
MNG-5560	2536,2	2261,9	2056,0	1801,7	1650,1	1432,9	1267,6	1128,5	920,0	
MNG-6050	3218,5	2816,3	2558,4	2239,8	2058,9	1745,0	1581,7	1400,0	1129,5	
MNG-7500	3829,0	3350,4	3043,6	2664,6	2449,3	2075,9	1881,7	1665,5	1343,7	
MNG-9170	4183,1	3730,6	3390,9	2971,3	2720,7	2363,4	2091,0	1861,3	1516,7	
MNG-11200	5108,8	4556,4	4142,5	3629,1	3323,3	2886,8	2553,8	2273,7	1851,7	

	95%	97%	98%	99%	99.50%	99.90%	99.95%	99.99%	99.999%
A/N Ratios	2	2,3	2,4	2,7	3	4	4,1	5,2	8,4

Given flows are at 7 barg pressure with reference to 20°C and 1 bar atmospheric air suction as per ISO7183.

Technical Specifications

Model	Free Nitrogen Delivery @ Following Purity Level (m ³ /h)									
	95%	97%	98%	99%	99.50%	99.90%	99.95%	99.99%	99.999%	
MNG-10	2,7	2,2	1,9	1,5	1	0,8	0,7	0,5	0,2	Modular
MNG-20	4,4	3,5	3,1	2,4	2	1,3	1,1	0,8	0,4	
MNG-35	8,1	6,5	5,6	4,4	3,5	2,3	2,0	1,4	0,7	
MNG-60	13,5	10,8	9,4	7,3	6	3,8	3,4	2,4	1,2	
MNG-95	23,3	18,6	16,2	12,6	10,4	6,6	5,9	4,1	2,0	
MNG-120	31,0	24,8	21,6	16,8	13,9	8,8	7,8	5,5	2,7	
MNG-150	38,0	30,4	26,4	20,6	17,0	10,8	9,6	6,7	3,3	
MNG-250	60,5	48,3	42,1	32,7	27,1	17,2	15,2	10,6	5,3	
MNG-330	80,0	63,9	55,7	43,3	35,8	22,8	20,1	14,1	7,0	
MNG-450	108,2	86,4	75,2	58,5	48,4	30,8	27,2	19,0	9,5	
MNG-510	123,9	99,0	86,2	67,1	55,5	35,3	31,2	21,8	10,9	
MNG-570	137,6	109,9	95,7	74,5	61,6	39,2	34,6	24,2	12,1	
MNG-730	180,1	143,9	125,3	97,5	80,6	51,3	45,3	31,6	15,8	
MNG-910	220,3	176,0	153,2	119,2	98,6	62,7	55,5	38,7	19,3	
MNG-1110	267,8	214,0	186,3	145,0	119,9	76,2	67,4	47,0	23,5	
MNG-1230	295,4	236,0	205,5	159,9	132,3	84,1	74,4	51,9	25,9	
MNG-1370	327,4	261,5	227,7	177,2	146,6	93,2	82,4	57,5	28,7	
MNG-1820	442,6	353,6	307,9	239,6	198,2	126,0	111,4	77,8	38,8	
MNG-2050	516,2	412,4	359,0	279,4	231,1	146,9	130,0	90,7	45,3	
MNG-2550	618,8	494,4	430,4	334,9	277,1	176,1	155,8	108,7	54,3	
MNG-2950	763,2	609,8	530,9	413,1	341,8	217,2	192,1	134,1	67,0	
MNG-3540	894,5	714,6	622,1	484,1	400,5	254,6	225,1	157,1	78,5	
MNG-4160	1031,4	824,1	717,4	558,3	461,9	293,6	259,6	181,2	90,5	
MNG-5560	1241,7	992,0	863,6	672,1	556,0	353,4	312,5	218,1	109,0	
MNG-6050	1532,6	1224,5	1066,0	829,6	686,3	436,2	385,8	269,2	134,5	
MNG-7500	1823,3	1456,7	1268,2	986,9	816,4	519,0	458,9	320,3	160,0	
MNG-9170	2048,0	1636,1	1424,3	1108,4	917,0	582,9	515,5	359,7	179,7	
MNG-11200	2501,2	1998,3	1740,0	1353,8	1120,0	712,0	629,6	439,4	219,4	Twin Tower

Reference Conditions

Inlet Compressed Air Pressure	Outlet Nitrogen Pressure	Ambient Temperature	Inlet Air Dew Point	Purity
7.5 bar	6 bar	25°C	≤ 3°C	99.5%

N₂ NITROGEN

Model	Buffer Tank Volume	Buffer Tank	Connections		Dimensions (mm)		
			Air Inlet	Nitrogen Outlet	Width	Length	Height
MNG-10	26 L	GELM-100	1/2"	1/4"	610	1500	1090
MNG-20	35 L	GELM-100	1/2"	1/4"	675	1150	1308
MNG-35	52 L	GELM-100	1/2"	1/4"	736	1179	1787
MNG-60	70 L	GELM-100	1/2"	1/4"	932,5	1115,5	1485
MNG-95	97 L	GELM-250	1"	1/4"	920	1090	1485
MNG-120	126 L	GELM-300	1"	1/4"	1260	955	1450
MNG-150	151 L	GELM-500	1"	1/4"	1230	954	1650
MNG-250	280 L	ELM 150	1"	1/4"	1298	1256	1971
MNG-330	408 L	ELM 150	1"	1/4"	1520	1477	2023
MNG-450	464 L	ELM 150	1"	1/4"	1555	1423	2155
MNG-510	515 L	ELM 300	1 1/2"	1/4"	1560	1582	2022
MNG-570	573 L	ELM 300	1 1/2"	1/4"	1582	2208	2225
MNG-730	712 L	ELM 300	1 1/2"	3/4"	1945	1812	2082
MNG-910	1,042 m ³	ELM 300	1 1/2"	1"	1945	1812	2477
MNG-1110	1,290 m ³	ELM 600	1 1/2"	1"	2010	1872	2525
MNG-1230	1,402 m ³	ELM 600	2"	1"	2052	1909	2735
MNG-1370	1,498 m ³	ELM 600	2"	1 1/4"	2052	1903	2945
MNG-1820	2,019 m ³	ELM 600	2"	1 1/2"	1668	3599	2634
MNG-2050	2,336 m ³	ELM 800	DN80	1 1/2"	1841	3490	3120
MNG-2550	-	ELM 1200	DN80	2"	1920	2430	3185
MNG-2950	-	ELM 1200	DN80	2"	2070	2580	2630
MNG-3540	-	ELM 1600	DN80	2"	2120	2492	3055
MNG-4160	-	ELM 1600	DN80	2"	2176	2484	3375
MNG-5560	-	ELM 2100	DN 100	2 1/2"	2860	3490	3942
MNG-6050	-	ELM 2100	DN100	DN80	3260	3554	4145
MNG-7500	-	ELM-2750	DN100	DN80	3260	4164	4255
MNG-9170	-	ELM 4200	DN 100	DN80	3371	4746	4420
MNG-11200	-	ELM 4200	DN 150	DN100	3130	5091	4772

Note: Mikropor supplies buffer tank volumes for 99,0% and higher Nitrogen purities. For purities lower than 99,0%, it may be necessary to use an additional tank. (Buffer Tanks are standard for MNG 10 to MNG 2550)

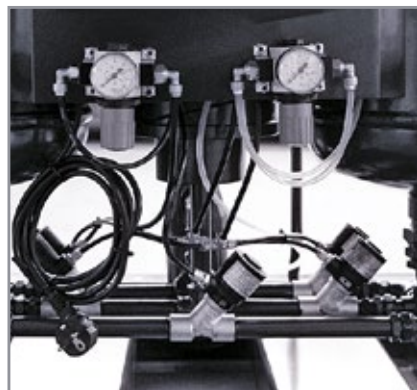

Correction Factor for MNG Series

Inlet Pressure (bar)	F1	Ambient Temp. (°C)	F2
6	0,82	5	0,85
6,5	0,88	10	1
7	0,94	15	1
7,5	1	20	1
8	1,05	25	1
8,5	1,1	30	0,91
9	1,14	35	0,82
9,5	1,2	40	0,74
10	1,21	45	0,6

To determine the nitrogen generator model in the reference conditions divide the nitrogen flow rate to the factors mentioned above.

"Mikropor reserves the right to change the design and/or dimensions and/or weight of his products at any time without any notice or liability."

AIR LINE DESIGN

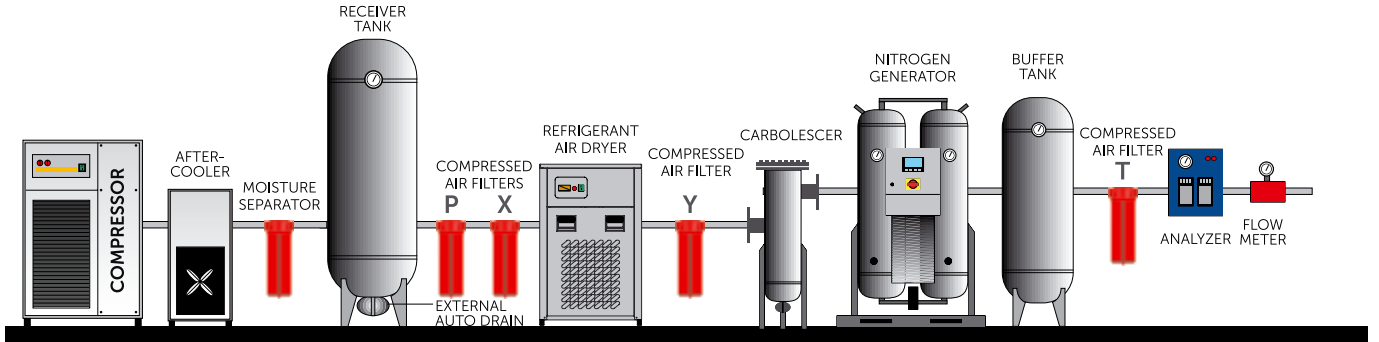

AIR LINE DESIGN

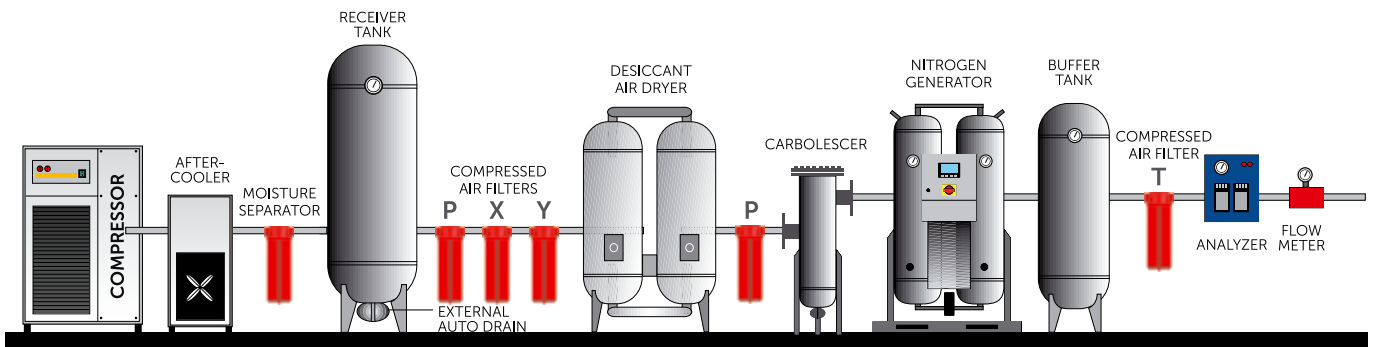

▶ MDX SERIES NITROGEN PURIFIER SYSTEM

Most PSA Nitrogen Generator users require the highest levels of Nitrogen purity by the most cost-effective means possible.

Mikropor's brand new MDX Nitrogen Purifier System offers an extremely economic way to increase Nitrogen purity levels beyond 99.5% or 99.9% all the way up to 99.999% purity.

The MDX range increases Nitrogen purities by utilizing a specially designed catalyst with a large surface area. As a result of the reaction on the catalyst surface, the residual oxygen content is reduced to maximum 10 ppm level.

Mikropor's MDX Nitrogen Purifiers, combined with Mikropor's MNG Nitrogen Generators, utilise a small amount of Hydrogen gas during the reaction process to achieve high levels of Nitrogen purity by avoiding compressed air loss.

The MDX System, in conjunction with MNG Nitrogen Generators, will significantly reduce power consumption and still achieve the highest possible levels of Nitrogen purity.

Working Principle

In comparison to the current applications, Nitrogen produced from a nitrogen generator at 99.5% or 99.9% purity level can be converted to 99.999% by Mikropor's compact design Nitrogen Purifier System which also provides high savings in nitrogen production costs.

The system uses a catalytic reaction, whereby residual Oxygen from the MNG generator is removed from the PSA Nitrogen Generator output by utilising a reaction between the remaining Oxygen and Hydrogen gas to produce a purity of 99.999% Nitrogen. The only by-product of this catalytic reaction is water.

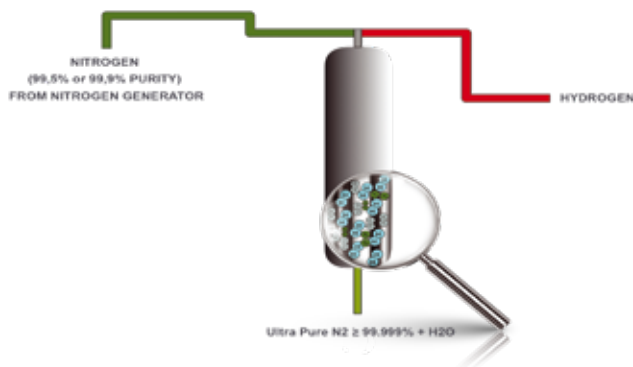

The total cost of hydrogen required for the reaction is very low and provides significant long-term savings.

High purity nitrogen can in fact be produced by utilizing lower capacity air compressors and downstream equipments throughout this newly developed nitrogen purification process.

The reaction increases the Nitrogen temperature. That is why Mikropor's MDX Nitrogen Purifier System has been integrated into a High Temperature Air Dryer combining two products into a single unit to give a complete solution.



Inlet Nitrogen Purity (99.5% or 99.9%)

Model	MDX - 10	MDX - 20	MDX - 35	MDX - 60	MDX - 95	MDX - 120	MDX - 150	MDX - 250	MDX - 330
N ₂ Flow at 99.999% Purity (m ³ /h)	1	2	3.5	6	10.4	13.9	17	27.1	35.8
Model	MDX - 450	MDX - 510	MDX - 570	MDX - 730	MDX - 910	MDX - 1110	MDX - 1230	MDX - 1370	MDX - 1820
N ₂ Flow at 99.999% Purity (m ³ /h)	48.4	55.5	61.6	80.6	98.6	119.9	132.3	146.6	198.2

Nitrogen	99.999%
Oxygen	<10 ppm
Dew Point*	<3°C
*: -40°C Optional	

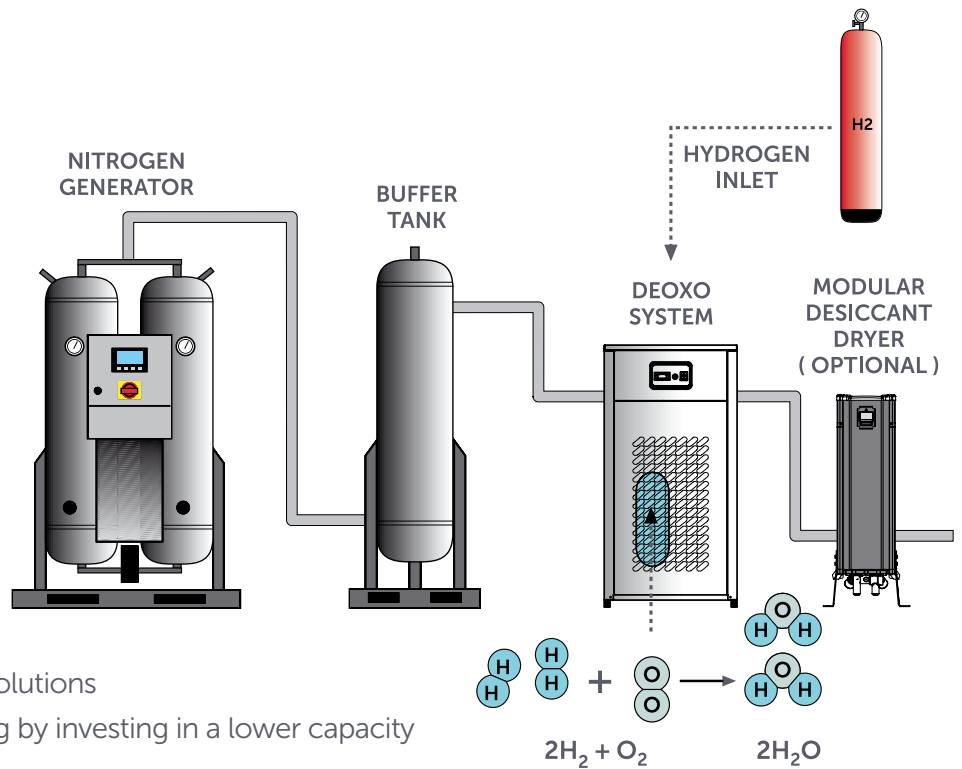

Advantages

- Effective pay-back period
- Minimised installation area
- Long life efficiency (> 10 years)
- Top-quality high-performance solutions
- Cost reduction and Power Saving by investing in a lower capacity MDX rather than installing a higher capacity MNG system solely for the same N2 purity level.
- Up to 99.999% nitrogen purity with minimum space and energy requirement
- Low energy consumption
- Low CO2 emission
- Heavy-duty construction designed for rough conditions and industrial use
- High quality & durable components
- System that delivers min. 99.999% purity with a very low A/N (air : nitrogen) ratio (3.0 instead of 8,4)
- Compact design, fully automatic system
- 24/7 Nitrogen gas production in desired purities
- High energy saving
- Low cost and customized production
- Minimum maintenance cost

SYSTEM	COMPRESOR + DRYER + MNG + DEOXO	COMPRESOR + DRYER + MNG
Required Compressor Power (kW)	37,0	90,0
Compressor Cost (EURO)	13970,0	33850,0
Dryer Model Number	MKE-375	MKE-930
Dryer Cost (EURO)	2162,0	3861,0
Nitrogen Generator Model	MNG-1110	MNG-5560
MNG Nitrogen Generator Cost (EURO)	39200,0	111700,0
Deoxo Unit Model Number	MDX-1230	-
Deoxo Unit Cost (EURO)	67252,0	-
Total Investment Cost	122.584 EUR	149.411 EUR
Total Investment Cost Saving	26.827 EUR	

Annual N2 Production Cost	53.832 EUR	55.188 EUR
Investment Pay Back Period (year) (Compared to liquid)	0,7	0,8
Investment Pay Back Period (year) (Compared to manifold)	0,3	0,4

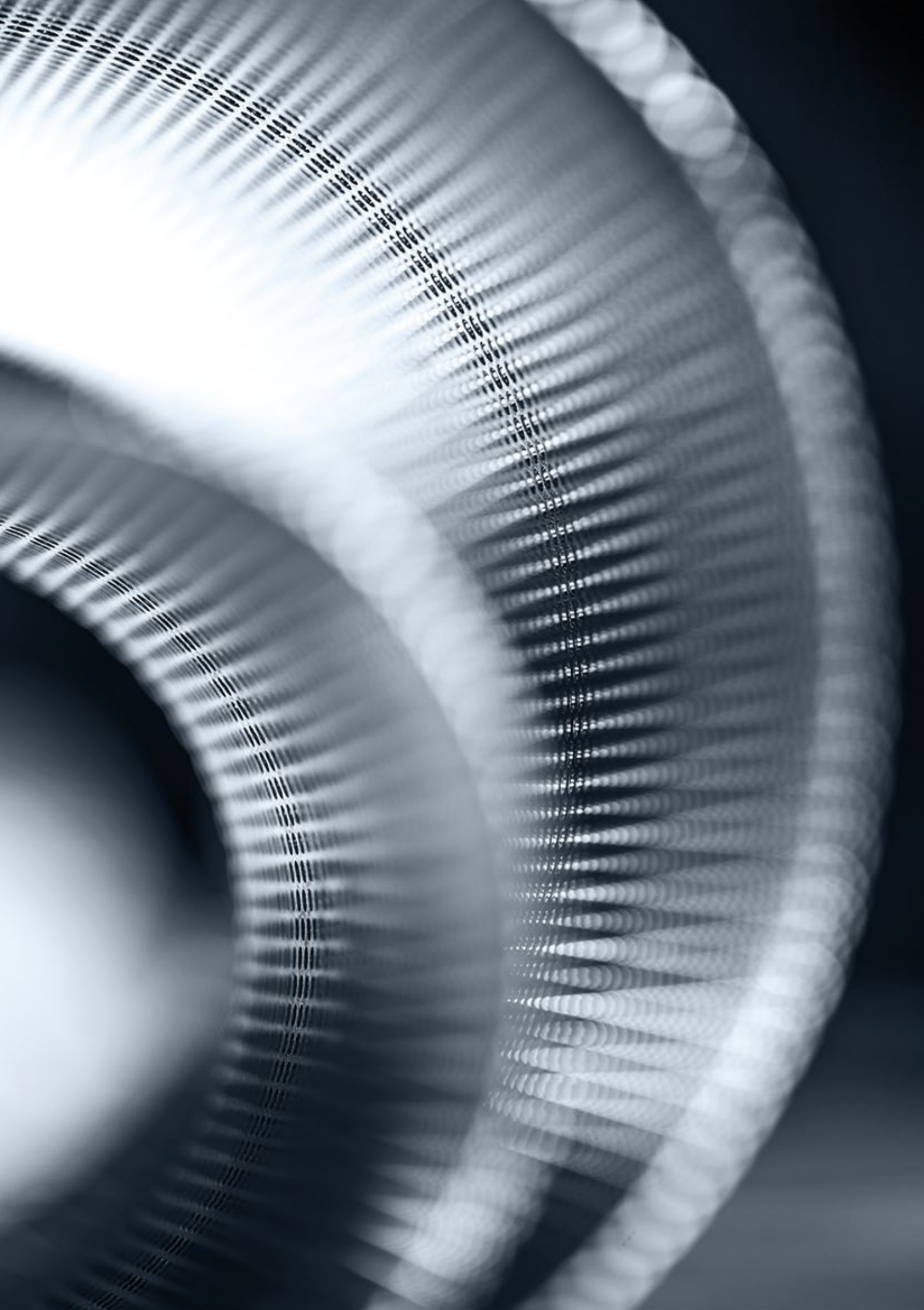

MCT SERIES ACTIVATED CARBON TOWER

Many industries such as the electronic and hospital industries, pharmaceutical industries, food and beverage sectors require the removal of residual oil vapors and odors from the compressed air. Mikropor's solution for this application is the MCT Series activated carbon towers. With standard pre and after filters such as particulate filters, water coalescers and oil coalescers, the oil content inside the compressed air can be reduced to 0.01 mg/m³ (0.01 ppm) for applications of EXTREME air quality such as hospital, pharmaceutical industries, or food and beverage industries, the residual oil content may need to be reduced to 0.003 mg/m³ (0.003 ppm). MCT filters such as Mikropor activated carbon G series, GO series, F series filters or MCT activated carbon towers are a must for these types of applications.

Correction Factor

Operating Pressure (bar)	PSI	Correction Factor
1	15	0,5
3	44	0,71
5	73	0,87
7	100	1
9	131	1,12
10	145	1,15

Max. Recommended Operating Temperature	Max. Oil Carryover at 21°C (mg/m ³)	Max. Working Pressure
50°C	0,003°C	10 bar

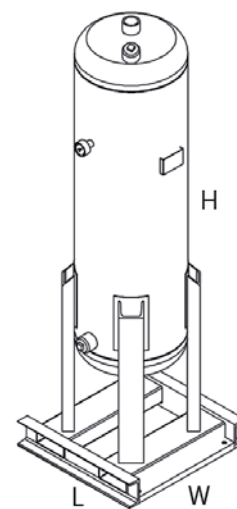
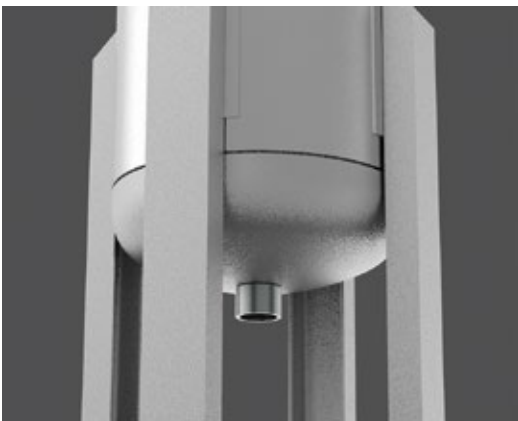

Technical Specifications

Model	Connection Size	Flow Rate (m ³ /h)	Max. Working Pressure (bar)	Activated Carbon (kg)	Housing Dimensions (mm)		
					Length	Width	Height
MCT130	1"	130	10	14	347	450	1172
MCT185	1"	185	10	20	450	563	1413
MCT250	1"	250	10	28	430	601	1370
MCT300	1 1/2"	300	10	37	500	649	1336
MCT360	1 1/2"	360	10	37	500	649	1336
MCT440	1 1/2"	440	10	46	500	648	1536
MCT575	1 1/2"	575	10	56	469	604	1733
MCT680	2"	680	10	74	550	540	1936
MCT850	2"	850	10	97	580	600	1957
MCT1000	2"	1000	10	128	657	638	1617
MCT1250	DN80	1250	10	149	708	880	2400
MCT1500	DN80	1500	10	167	708	880	2558
MCT1800	DN80	1800	10	210	810	980	2423
MCT2200	DN80	2200	10	262	810	1100	2600
MCT2700	DN80	2700	10	320	910	1100	2758
MCT3200	DN100	3200	10	356	866	1050	3023
MCT3600	DN100	3600	10	400	866	1050	3237
MCT4400	DN100	4400	10	537	1130	1250	2914
MCT5000	DN100	5000	10	624	1130	1310	3420
MCT6300	DN150	6300	10	754	1230	1230	3365
MCT7200	DN150	7200	10	845	1430	1430	3075
MCT8800	DN150	8800	10	1009	1430	1430	3369
MCT10800	DN200	10800	10	1148	1430	1430	3863

Given flows are at 7 barg pressure with reference to 20°C and 1 bar atmospheric air suction as per ISO7183.

MBS SERIES BREATHING AIR SYSTEM

Breathing Air Solutions

High-quality compressed air is crucial to many industries and has a vital role in breathing air applications. Mikropor breathing air purifiers are designed to eliminate hazardous substances in the air conforming to related standards. (Mikropor breathing air purifiers are designed to protect against a range of contaminants that may be present in a compressed air fed breathing air system.)



Technical Specifications

Model	Capacity		Connection Size	Replacement Filter Kit Model	Voltage	Max. Working Pressure (bar)
	(m ³ /h)	(cfm)				
MBS 5	10	5	1/2"	G100-ELM	115-240V/50-60Hz.	16
MBS 10	20	10	1/2"	G100-ELM	115-240V/50-60Hz.	16
MBS 15	25	15	1/2"	G100-ELM	115-240V/50-60Hz.	16
MBS 20	35	20	1/2"	G100-ELM	115-240V/50-60Hz.	16
MBS 25	45	25	1/2"	G150-ELM	115-240V/50-60Hz.	16
MBS 30	50	30	1/2"	G200-ELM	115-240V/50-60Hz.	16
MBS 40	70	40	1 1/2"	G250-ELM	115-240V/50-60Hz.	16
MBS 50	85	50	1 1/2"	G300-ELM	115-240V/50-60Hz.	16
MBS 60	100	60	1 1/2"	G500-ELM	115-240V/50-60Hz.	16
MBS 75	130	75	1 1/2"	G600-ELM	115-240V/50-60Hz.	16
MBS 100	170	100	1 1/2"	G851-ELM	115-240V/50-60Hz.	16
MBS 120	200	120	1 1/2"	G1210-ELM	115-240V/50-60Hz.	16
MBS 180	300	180	1 1/2"	ELM 300	115-240V/50-60Hz.	16
MBS 240	400	240	1 1/2"	ELM 300	115-240V/50-60Hz.	16
MBS 250	440	250	1 1/2"	ELM 300	115-240V/50-60Hz.	16
MBS 300	575	300	1 1/2"	ELM 600	115-240V/50-60Hz.	16
MBS 400	680	400	2"	ELM 600	115-240V/50-60Hz.	16
MBS 500	850	500	2"	ELM 600	115-240V/50-60Hz.	16
MBS 600	1000	600	2"	ELM 600	115-240V/50-60Hz.	16
MBS 700	1250	700	DN80	ELM 800	115-240V/50-60Hz.	16
MBS 800	1500	800	DN80	ELM 1200	115-240V/50-60Hz.	16
MBS 1000	1800	1000	DN80	ELM 1200	115-240V/50-60Hz.	16
MBS 1250	2200	1250	DN80	ELM 1600	115-240V/50-60Hz.	16

Given flows are at 7 barg pressure with reference to 20°C and 1 bar atmospheric air suction as per ISO7183.

Contaminants	CSA Z180.1	European Pharmacopoeia	OHSA Grade D
Water	Pressure dew point of 5°C below lowest system temp.	67 ppm (-45°C atmospheric dew point)	-
Oil/Lubricant	<1 mg/m ³	0,1 mg/m ³	5 mg/m ³
Carbon Dioxide (CO ₂)	<500 ppm	<500 ppm	<1000 ppm
Carbon Monoxide (CO)	<5 ppm	<5 ppm	<10 ppm
Nitrogen Oxides (NO+NO ₂)	-	<2 ppm	-
Sulphur Dioxide (SO ₂)	-	<1 ppm	-
Oxygen (O ₂)	-	21±1	-
Taste and Odor	-	Free	-



I. OSB Oğuz Caddesi No: 5, 06935, Ankara-Turkey

+90 312 267 0700 +90 312 267 0552 mikropor@mikropor.com

  mikropor

www.mikropor.com